

1134 Wireless Wiegand Module

INSTALLATION AND PROGRAMMING GUIDE

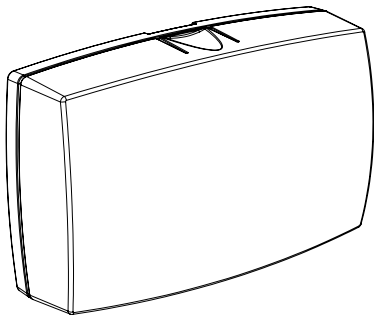

TABLE OF CONTENTS

About the 1134	1	Program the 1134 Options.....	15
Power Supply	1	Program Start Display	15
Zone Terminals	1	Serial Number Display	15
Annunciators	1	Initialization Option	15
LED Indicators	1	Initialize Confirm Option	16
LED Survey	2	Activate Zone 2 Bypass	16
Form C Relay.....	2	Zone 2 Bypass Time	17
Programming Connection.....	2	Relock on Zone 2 Change.....	17
Dry/Wet Contact	2	Activate Zone 3 Request to Exit	18
PCB Features.....	3	Zone 3 REX Strike Time	19
Program the 1134	4	Activate Onboard Speaker	19
Part 1: Device Setup.....	4	Custom Card Definitions	20
Part 2: Zone Information	5	Any Card Format.....	20
Install the 1134	6	Card Formats	20
Mount the 1134.....	6	Format Name.....	20
Wire the Electronic Lock.....	7	Wiegand Code Length.....	21
Isolation Relay	9	Site Code Position and Length	22
Install the 333 Suppressor	10	User Code Position and Length.....	22
Wire the Zone Terminals.....	11	Require Site Code	22
Connect a Card Reader.....	13	Site Code Display	23
		Number of User Code Digits.....	23

No Communication with Panel24

Remove Keypad.....25

Public Card Formats 26

Product Specifications27

Readers and Credentials28

FCC Information 30

Industry Canada Information..... 31

ABOUT THE 1134

The 1134 Wireless Wiegand Module allows you to use the powerful built-in access control capability of DMP panels. DMP panels provide access control, arming, and disarming using proximity, mag-stripe, biometric or other Wiegand-output authentication devices.

The 1134 connects and operates wirelessly with DMP panels. A keypad may be plugged directly into the 1134 for local programming. The 1134 includes the following features:

POWER SUPPLY

The 1134 operates at 12/24 VDC from the power supply supporting a door's magnetic lock or door-strikes. It also provides a 10 Amp Form C relay contact for lock control.

ZONE TERMINALS

The 1134 has four onboard zones that can be programmed for a variety of burglary or access control applications.

ANNUNCIATORS

An on-board programmable piezo provides local annunciation at the 1134. You can also connect a variety of switched ground annunciators to the 1134 for remote annunciation.

LED INDICATORS

The 1134 provides two indicator LEDs. The SURVEY (Red) LED turns on for the same duration as the door strike relay. The WIEGAND (Yellow) LED turns on for one second to indicate receipt of a valid Wiegand input.

LED SURVEY

The 1134 provides a Survey LED capability to allow one person to confirm communication with the wireless receiver while the cover is removed.

Mount the 1134 away from large metal objects because it may impair performance. Do not mount the 1134 inside a metal enclosure or install in a drop ceiling.

1. With the cover removed, hold the 1134 in the exact desired location.
2. Press the tamper switch to send data to the panel and determine if communication is confirmed or faulty.

✓ **Confirmed:** If communication is confirmed, for each press or release of the tamper switch, the LED blinks immediately on and immediately off.

✗ **Faulty:** If communication is faulty, the LED remains on for about 8 seconds or flashes multiple times in quick succession. Relocate the 1134 or receiver until the LED confirms clear communication.

FORM C RELAY

The 1134's Form C relay draws up to 35 mA of current. Refer to the NC/C/NO (Dry Contact Relay) and the Isolation Relay sections in this document for more information.

PROGRAMMING CONNECTION

The 1134 provides a keypad programming connection that allows you to use a standard DMP LCD keypad for initial setup.

DRY/WET CONTACT

Apply power to the door relay (WET setting) or leave it unpowered (DRY setting).

PCB FEATURES

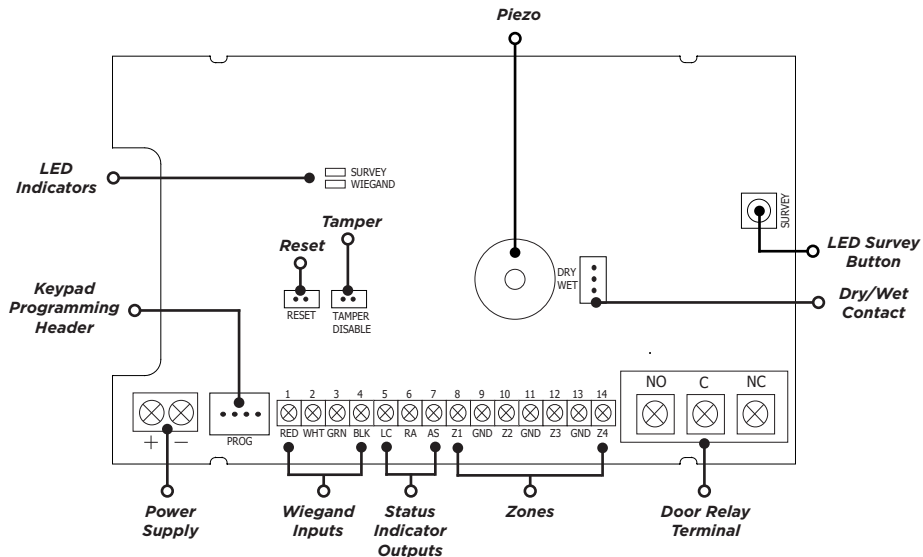

Figure 1: PCB Features

PROGRAM THE 1134

Refer to the panel programming guide as needed.

1. Reset the panel.
2. At the keypad, enter **6653** (PROG) to access the **PROGRAMMER** menu.

PART 1: DEVICE SETUP

1. In **DEVICE SETUP**, press **CMD** until you get to **DEVICE NO: -**.
2. Enter a **DEVICE NO:-** and press **CMD**.
3. Enter a **DEVICE NAME** and press **CMD**.
4. (XT30/XT50 only) Select **YES** when **WIRELESS?** displays.
5. (XR150/XR550 only) Select **DOOR** for **DEVICE TYPE** and press **CMD**.
6. (XR150/XR550 only) Select **WLS** at **COMM TYPE** and press **CMD**.
Note: Panel version 191 or higher software is required.
7. Enter the eight-digit **SERIAL#:-** and press **CMD**.
Note: Enter the Type 14 serial number found on the 1134 PCB or by connecting a keypad to the header on the 1134.
8. Enter the **SUPRVSN TIME** and press **CMD**.

PART 2: ZONE INFORMATION

1. In **ZONE INFORMATION**, enter the wireless **ZONE NO:** - and press **CMD**.
2. Enter the **ZONE NAME** and press **CMD**.
3. Select the **ZONE TYPE** and press **CMD**.
4. At **NEXT ZN?**, select **NO**.
5. Select **YES** when **WIRELESS?** displays.
6. Enter the eight-digit **SERIAL#:-** and press **CMD**.
Note: Enter the Type 08 serial number found on the 1134 PCB or by connecting a keypad to the header on the 1134.
7. Enter the **CONTACT** number being used.
8. Enter the **SUPRVSN TIME** and press **CMD**.
9. At the **NEXT ZN?** prompt, select **YES** and continue to program up to three more zones.
Note: Zones must be entered sequentially. For example, if you program zone 71, you need to program zone 72 as the next contact. Use the same serial number for each contact.

INSTALL THE 1134

1 MOUNT THE 1134

The 1134 comes in a high-impact plastic housing that you can mount directly to a wall, backboard, or other flat surface.

For easy installation, the back and ends of the 1134 housing have wire entrances. The back also contains multiple mounting holes that allow you to mount the 1134 on a single-gang switch box. DMP recommends mounting the 1134 near the protected door. Remove the PCB from the housing base to install the housing to the wall. See Figure 2 for mounting hole locations.

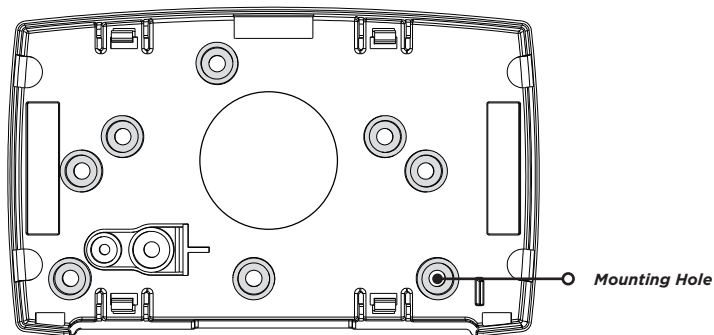

Figure 2: Mounting Hole Locations

2 WIRE THE ELECTRONIC LOCK

The 1134 provides a Form C (SPDT) relay for controlling locks and other electronically-controlled barriers. The three relay terminals marked **NO C NC** allow you to connect the device wiring to the relay for module control.

Use a power supply to power magnetic locks. See Figure 3. You can power door strikes either from a power supply (DRY contact) or from the 1134 (WET contact). See Figures 4a and 4b for door strike wiring.

The Form C relay draws up to 35 mA of current and contacts are rated for 10 Amps (resistive) at 12/24 VDC. When connecting multiple locks to the Form C relay, the total current for all locks cannot exceed 10 Amps. If the total current for all locks exceeds 10 Amps, problems may arise and an isolation relay may be needed. See the Isolation Relay section for information.

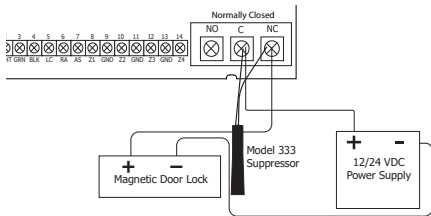

Figure 3: Typical Magnetic Lock Wiring

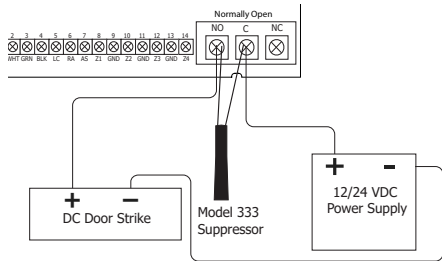
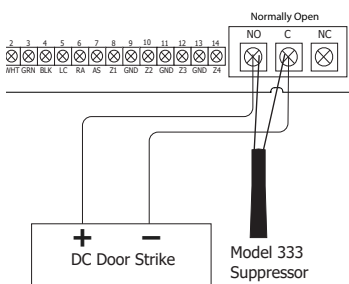

Figure 4a: Dry Door Strike Wiring

When the jumper on the 1134 is set to WET, the C terminal will pass 12 VDC through the C terminal. No additional power supply is needed. See Figure 4b.



**Figure 4b: Wet
Door Strike Wiring**

3 ISOLATION RELAY (optional)

The Form C relay can control a device that draws less than 10 Amps of current. If a device draws more than 10 Amp of current, or the sum of all devices controlled by the Form C relay exceeds 10 Amps, an isolation relay must be used. Refer to Figures 5 and 6 for isolation relay wiring.

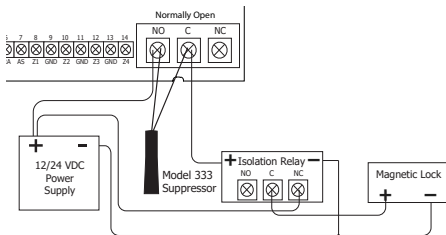

Figure 5: Magnetic Lock with an Isolation Relay

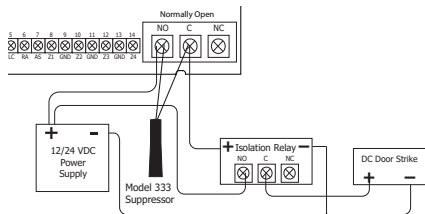

Figure 6: Door Strike with an Isolation Relay

4 INSTALL THE 333 SUPPRESSOR

Use the included 333 suppressor with the 1134 to suppress any surges caused by energizing a magnetic lock or door strike.

Install the 333 across the 1134 **C** (common) and **NO** (normally open) or **NC** (normally closed) terminals.

If the device being controlled by the relay is connected to the **NO** and **C** terminals, install the suppressor on the **NO** and **C** terminals.

Conversely, if the device is connected to the **NC** and **C** terminals, install the 333 Suppressor on **NC** and **C** terminals.

The suppressor wire is non-polarized. Install the suppressor as shown in Figure 7.

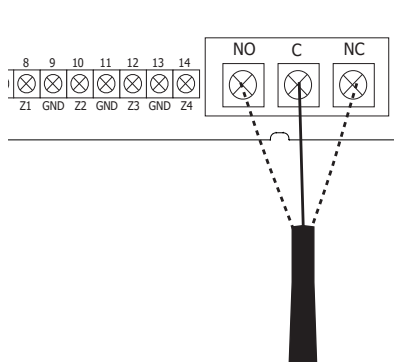

Figure 7: 333 Suppressor Installation on the 1134

5 WIRE THE ZONE TERMINALS

Terminals 8 through 14 connect grounded zones 1 through 4. These zones have a grounded side and cannot be used for fire-initiating devices. Zones 2 and 3 can also be used for access control with zone 2 providing a bypass feature and zone 3 providing Request to Exit functionality.

Use the supplied 311 1K Ohm end-of-line (EOL) resistors on each zone. Refer to the panel programming guide for programming instructions. See the table below and Figure 8 for more information on wiring the zone terminals.

ZONE #	RECOMMENDED DEVICE
1	Any burglary device
2	Door Contact
3	REX (PIR or Button)
4	Any burglary device

Table 1: 1134 Zone Uses

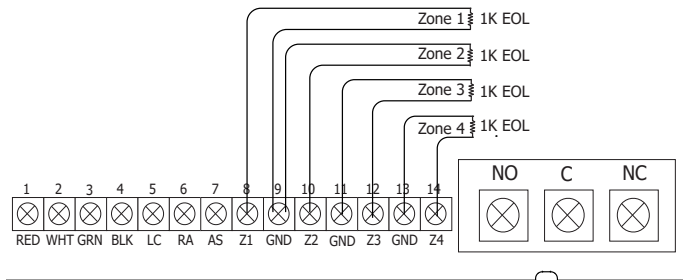

Figure 8: 1134 Zone Terminal Wiring

6 CONNECT A CARD READER *(optional)*

The 1134 provides direct 12/24 VDC, 200 mA output to the reader on the **RED** terminal connection. Figure 9 shows a reader with wire colors **RED**, **WHT**, **GRN**, and **BLK** connecting to terminals 1, 2, 3, and 4.

The green wire carries Data Zero (D0), and the white wire carries Data One (D1). The red wire connects 12/24 VDC, 200 mA maximum power and the black wire is ground.

The wire colors may be different depending on the reader being installed. Refer to the literature provided with the reader for wire coding, wire distance, cable type (such as shielded), and other specifications.

Card Reader LED Operation

To provide visual indication of a valid card read, the card reader can be wired to illuminate the green LED for the duration of the door strike.

Connect the orange or brown wire to **LC** terminal 5 to have the green LED stay on for the duration of the relay activation.

Card Reader Annunciation

Connect the yellow wire to **RA** terminal 6 to have the remote annunciator turn on anytime the panel instructs the 1134 on-board piezo to turn on.

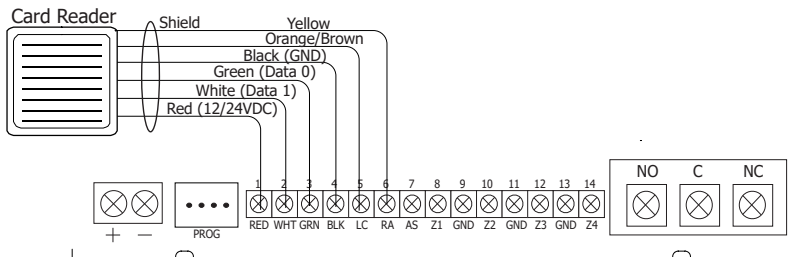

Figure 9: Card Reader Wiring

PROGRAM THE 1134 OPTIONS

When you program the 1134, you can use a keypad connected to the 1134 programming header and set to address 1. For 12 V applications, connect the keypad to the module using a Model 330 4-wire harness. For 24 V applications, connect the keypad to the module using a Model 330-24 4-wire programming harness with in-line resistor.



Do not connect a keypad using a standard Model 330 harness if using a 24 V power supply! Damage to the keypad could occur.

While the 1134 is in programming mode, it will not be able to communicate with the panel.

1134 PROGRAMMING
VER VVV MM/DD/YY

PROGRAM START DISPLAY

When you connect the keypad to the 1134 module, the version number and release date display. Press **CMD** to enter the **PROGRAMMER** menu.

SERIAL#:XXXXXXXX

SERIAL NUMBER DISPLAY

View the serial numbers for the 1134. The 1134 has a Type 14 and Type 08 serial number. Press **CMD** to view the second serial number.

INITIALIZE ALL?
NO YES

INITIALIZATION OPTION

These options can set the 1134 module programming memory back to factory defaults. Press any select key or area to enter the Initialization menu.

ARE YOU SURE?
YES NO

ACTIVATE ZONE 2
BYPASS? NO YES

INITIALIZE CONFIRM OPTION

After selecting **YES** to clear the Access Options, the 1134 displays **SURE? YES NO** for confirmation to clear the memory. This is a safeguard against accidentally erasing the programming. No memory is cleared from the programming until you answer **YES** to the **SURE?** option. Selecting **NO** leaves communication options unchanged.

ACTIVATE ZONE 2 BYPASS

Select **YES** to activate the zone 2 bypass operation. Selecting **NO** allows standard zone operation on zone 2. The default is **NO**.

If the door being released by the 1134 module is protected (contact installed), a programmable bypass entry/exit timer can be provided by connecting the contact wiring to the 1134 module zone 2. When the on-board Form C relay activates and the user opens the door connected to zone 2, the zone is delayed for the number of seconds programmed in **ZONE 2 BYPASS TIME** allowing the user to enter/exit during an armed period.

If zone 2 does not restore (door closed) within the programmed time, the piezo sounds every other second during the last ten seconds. If zone 2 restores prior to the end of the programmed time, the piezo silences. If the zone does not restore before the programmed time, the 1134 ends the bypass and indicates the open or short zone condition to the panel.

ZONE 2 BYPASS
TIME: **40**

ZONE 2 BYPASS TIME

Enter the number of seconds to elapse before the bypass timer expires. The range is 20-250 seconds. Press any select key or area to enter the number of seconds. The default is **40** seconds. Figure 12 shows how the bypass option works.

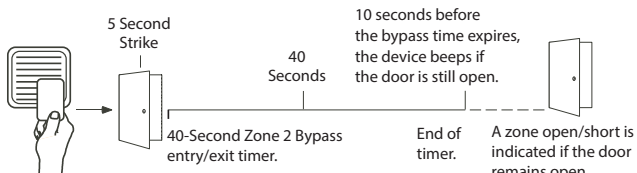

Figure 12: Zone 2 Bypass Timeline using default time

RELOCK ON ZONE 2
CHANGE? **NO** YES

RELOCK ON ZONE 2 CHANGE

Selecting **YES** turns the relay off when zone 2 changes state. Selecting **NO** leaves the relay on when zone 2 changes state. Turning off the relay at Door Closed allows a long strike time to be automatically ended and relocks the door. The default is NO.

ACTIVATE ZONE 3 REX? NO YES

ACTIVATE ZONE 3 REQUEST TO EXIT

Selecting **YES** activates the zone 3 Request to Exit (REX) option. Selecting **NO** allows standard zone operation on zone 3. Default setting is **NO**.

Connect a motion sensing device or a mechanical switch to zone 3 to provide REX capability to the system.

When zone 3 shorts, the on-board Form C relay activates for the programmed number of seconds. See Zone 3 REX Strike Time. During this time, the user can open the protected door to start the programmed zone 2 bypass entry/exit timer. After the programmed number of seconds, the relay restores the door to its locked state.

The 1134 module provides a bypass-only option for REX on zone 3. When zone 3 OPENS from a NORMAL state, only a bypass occurs: the on-board relay does not activate. This bypass-only option uses two methods of REX.

The first REX device provides the programmed bypass entry/exit timer. The second REX unlocks the door.

ZN 3 REX STRIKE
TIME:

5

ZONE 3 REX STRIKE TIME

Enter the number of REX seconds to elapse. Range is from 5 to 250 seconds. Press any select key or area to enter the number of seconds. The default is **5** seconds.

ACTIVATE ONBOARD
SPEAKER? **NO** YES

ACTIVATE ONBOARD SPEAKER

Select **YES** to enable the onboard piezo for local annunciation, such as alarm and trouble annunciations. Select **NO** to turn the speaker off for all operations. This does not affect remote annunciator open collector (RA) operation. The default is **NO**.

CUSTOM CARD DEFINITIONS

ANY CARD FORMAT
NO YES

ANY CARD FORMAT

Select **YES** to allow all card reads to activate the door strike relay. The door strike relay is activated for the length of time programmed in **ZN 3 REX TIME**. No user code information is sent to the panel. Default is **NO**.

CARD FORMATS
FORMAT NO: -

CARD FORMATS

Select the slot number (1-7) that you would like to program a custom non-DMP card format into. Select 8 if you would like to program a DMP card format. See Public Card Formats for some publicly available card formats that can be used with the 1134. Other private or custom formats may also be compatible. Please contact the credential supplier or manufacturer for the bit structure.

FORMAT NAME
UNUSED

FORMAT NAME

Press any select area to rename the card format. Press **CMD** to save and advance.

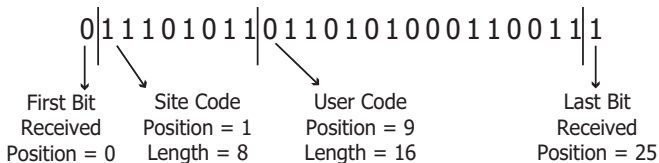

In this example the Wiegand Code Length = 26 bits.

Figure 13: Wiegand Data Stream Bit Location

WEIGAND CODE LENGTH: 26

WIEGAND CODE LENGTH

When using a custom credential, enter the total number of bits to be received in Wiegand code including parity bits.

Press any select key or area to enter a number between 1-255 to equal the number of bits. Default is **26** bits.

An access card contains data bits for a site code, user code, and start/stop/parity bits. The starting position, location, and code length must be determined and programmed into the keypad. See Figure 13.

SITE CODE

POS: **1** LEN: **8**

SITE CODE POSITION AND LENGTH

Enter the site code start position and length in the data string. Press select area 2 to clear the site code start position and enter a number between 0-255. Press **CMD** to save. Default is **1**.

Press select area 4 to clear the site code length and enter a number between 1-24. Press **CMD** to save. Default is **8**.

USER CODE

POS: **9** LEN: **16**

USER CODE POSITION AND LENGTH

Define the user code start bit position and length. Press select area 2 to clear the user code position and enter a number between 0-255. Press **CMD** to save. Default is **9**.

Press select area 4 to clear the user code length and enter a number between 16-64. Press **CMD** to save. The default is the DMP value of **16**.

REQUIRE SITE

CODE?: **NO** YES

REQUIRE SITE CODE

Press the top row select key or area under **YES** to use a site code and press **CMD** to view the site code entry display. Press **NO** to advance to **NO OF USER CODE DIGITS**. Default is **NO**.

In addition to user code verification, door access is only granted when any one site code programmed at the **SITE CODE ENTRY** option matches the site code received in the Wiegand string.

SITE CODE 1:

SITE CODE DISPLAY

You can program up to eight 8-digit site codes. The site code range is 0-16,777,214.

In the keypad display, enter site code 1 and press CMD. The display will ask for site code 2 followed by site code 3 and so on. When you have selected the site code you want to change, press **CMD**.

NO OF USER CODE
DIGITS: **5**

NUMBER OF USER CODE DIGITS

The 1134 module recognizes user codes from 4-12 digits long. Press any top row select key or area to enter a user code digit length. This number must match the user code number length being programmed in the panel. Default is **5**.

All bits are read and converted into a decimal number string. The number string is left padded with '0' if needed for long user code lengths. When selecting '4' the right digit is dropped and the next four sent.

Example:	# decoded	1234567
	10 digits	0001234567
	5 digits	34567
	4 digits	3456

NO COMM WITH PNL
OFF SITE ANY ON

NO COMMUNICATION WITH PANEL

Define the relay action when communication with the panel has not occurred for 5 seconds. Default is **OFF**. Press any select key or area to change the default relay action:

Press the first select key or area to choose **OFF** (Relay Always Off) — The relay and Wiegand LED do not turn on when any Wiegand string is received. **OFF** does not affect any REX operation. If communication is lost during a door strike, the relay remains on for the door strike duration but turns off at the end of the door strike timer.

Press the second select key or area to choose **SITE** (Accept Site Code) — Door access is granted when the Wiegand site code string received matches any site code programmed at **SITE CODE DISPLAY**. Refer to **REQUIRE SITE CODE** for more information.

Press the third select key or area to choose **ANY** (Any Wiegand Read) — Access is granted when any Wiegand string is received.

Press the fourth select key or area to choose **ON** (Relay Always On) — The relay is always on.

Press **CMD** to display the next action.

Press the first select key or area to choose **LAST** (Keep Last State) — The relay remains in the same state and does not change when communication is lost.

NO COMM WITH PNL
LAST

REMOVE KEYPAD

REMOVE KEYPAD

The **REMOVE KEYPAD** option continually displays with no time out while the keypad remains connected to the 1134 module after programming is finished. After five seconds, the 1134 module piezo continually sounds if the keypad remains connected and programming is finished. Remove the keypad harness to disconnect the keypad from the 1134 module and silence the alarm.

PUBLIC CARD FORMATS

CARD FORMAT	WIEGAND CODE LENGTH	SITE CODE POSITION	SITE CODE LENGTH	USER CODE POSITION	USER CODE LENGTH	USER CODE DIGITS
H10301 26 BIT	26	1	8	9	16	5
H10302 37 BIT W/FAC	37	1	16	17	19	6
H10304 37 BIT W/O FAC	37	0	0	1	35	12
FARPOINTE 39 BIT	39	1	17	18	20	7
CORPORATE 1000 35 BIT	35	2	12	14	20	6
CORPORATE 1000 48 BIT	48	2	22	24	23	7

PRODUCT SPECIFICATIONS

Primary Power	8.5 VDC to 28.5 VDC
Current Draw	
Standby	220 mA (includes 200 mA for proximity reader)
Peak	230 mA (includes 200 mA for proximity reader)
Reader Current	up to 200 mA
Zones	5 VDC, 2 mA max
Dimensions	4.5 W x 2.75 H x 1.75 D in 11.43 W x 7 H x 4.45 D cm
Weight	8 oz .23 kg

READERS AND CREDENTIALS

125 KHZ PROXIMITY READERS	
P-300	CASCADE PROXIMITY READER
P-500	ALPS PROXIMITY READER
P-640	PATAGONIA PROXIMITY READER WITH KEYPAD
MP-5365	MINIPROX™ PROXIMITY READER
MX-5375	MAXIPROX® PROXIMITY READER
PP-6005B	PROXPOINT® PLUS PROXIMITY READER
PP-5355	PROXPRO PROXIMITY READER WITH KEYPAD
PR-5455	PROXPRO® II PROXIMITY READER
TL-5395	THINLINE II® PROXIMITY READER

125 KHZ PROXIMITY CREDENTIALS	
PSC-1	STANDARD LIGHT PROXIMITY CARD
PSK-3	PROXIMITY KEY RING TAG
PSM-2P	ISO IMAGEABLE PROXIMITY CARD
1306	PROX PATCH™
1326	PROXCARD II® CARD
1346	PROXKEY III® ACCESS DEVICE
1351	PROXPASS®
1386	ISOPROX II® CARD

13.56 MHZ SMARTCARD READERS

DELTA3	FARPOINTE SMARTCARD READER
DELTA5	FARPOINTE SMARTCARD READER
DELTA5.3	FARPOINTE SMARTCARD READER
DELTA6.4	FARPOINTE SMARTCARD READER

13.56 MHZ SMARTCARD CREDENTIALS

DC1-1	FARPOINTE CLAMSHELL SMARTCARD
DM1-3	FARPOINTE IMAGEABLE SMARTCARD
DE2	FARPOINTE MIFARE® DESFIRE® EV1 SMARTCARD
DK1-3	FARPOINTE KEY FOB SMARTCARD

FCC INFORMATION

This device complies with Part 15 of the FCC Rules. Operation is subject to the following two conditions:

1. This device may not cause harmful interference, and
2. This device must accept any interference received, including interference that may cause undesired operation.

Changes or modifications made by the user and not expressly approved by the party responsible for compliance could void the user's authority to operate the equipment.



Note: This equipment has been tested and found to comply with the limits for a Class B digital device, pursuant to part 15 of the FCC Rules. These limits are designed to provide reasonable protection against harmful interference in a residential installation. This equipment generates, uses and can radiate radio frequency energy and, if not installed and used in accordance with the instructions, may cause harmful interference to radio communications. However, there is no guarantee that interference will not occur in a particular installation. If this equipment does cause harmful interference to radio or television reception, which can be determined by turning the equipment off and on, the user is encouraged to try to correct the interference by one or more of the following measures:

- Reorient or relocate the receiving antenna.
- Increase the separation between the equipment and receiver.
- Connect the equipment into an outlet on a circuit different from that to which the receiver is connected.
- Consult the dealer or an experienced radio/TV technician for help.

INDUSTRY CANADA INFORMATION

This device complies with Industry Canada Licence-exempt RSS standard(s). Operation is subject to the following two conditions:

1. This device may not cause interference, and
2. This device must accept any interference, including interference that may cause undesired operation of the device.

Le présent appareil est conforme aux CNR d'Industrie Canada applicables aux appareils radio exempts de licence. L'exploitation est autorisée aux deux conditions suivantes:

1. l'appareil ne doit pas produire de brouillage, et
2. l'utilisateur de l'appareil doit accepter tout brouillage radioélectrique subi, même si le brouillage est susceptible d'en compromettre le fonctionnement.

