

1106 SERIES WIRELESS UNIVERSAL TRANSMITTERS

Installation Guide

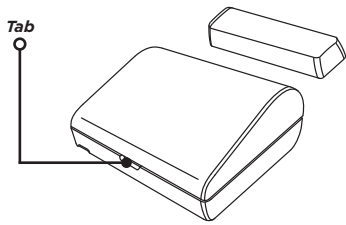

Figure 1: 1106 Housing

DESCRIPTION

The 1106 Series Wireless Universal Transmitters are wireless, two-input transmitters typically used for door and window applications. The 1106E features 128-bit AES encryption.

The 1106 Series provides a cover tamper, magnetic reed switch, and an on-board terminal block to allow for external contact wiring.

Both contacts, internal and external, can be programmed to operate at the same time. This allows two independent zones to operate from one 1106.

The 1106 Series also features Disarm/Disable functionality. When this option is set to YES, Zone Tripped messages are disabled when the system is disarmed to allow for extended transmitter battery life. Supervision, Tamper, and Low Battery are the only messages that are sent to the panel when the system is disarmed.

Compatibility

All DMP XT Series and XR Series and all 1100 Series Wireless Receivers.

To enable encryption on 1106E models, Version 183 is required for XT and XR Series panels and Version 300 is required for Wireless Receivers.

What is Included?

- One 1106 Wireless Universal Transmitter
- One magnet with standard and commercial housing and base
- One 3.0V lithium CR123A battery
- Hardware pack
- Double-sided tape



1 PROGRAM THE PANEL

Refer to the panel programming guide as needed.

1. At a keypad, enter 6653 (PROG) to access the Programmer Menu.

 **Note:** Steps 2 and 3 are for the 1106E to enable encryption. If using an 1106, proceed to step 4 to continue the installation.

2. (1106E only) Navigate to System Options. At the **1100 ENCRYPTION** prompt, select **ALL** to only add encrypted wireless devices to the system. Select **BOTH** to allow both encrypted and non-encrypted wireless devices to be programmed.
3. (1106E only) The default passphrase appears at the **ENTER PASSPHRASE** prompt. Press **CMD** to keep the default. Press any select key or area to change the passphrase and enter an 8-character hexadecimal string (0-9, A-F).
4. In **ZONE INFORMATION**, enter the wireless **ZONE NO:** and press **CMD**.
5. Enter the **ZONE NAME** and press **CMD**.
6. Select the **ZONE TYPE** and press **CMD**.
7. At the **NEXT ZN?** prompt, select **NO**.
8. Select **YES** when **WIRELESS?** displays.
9. Enter the eight-digit **SERIAL#** and press **CMD**.
10. At **CONTACT**, select either **INTERNAL** or **EXTERNAL**.

 **Note:** Use consecutive zone numbers if using both internal and external contacts.

11. If **EXTERNAL** was chosen in Step 7, choose **NO** or **YES** at the **NORM OPEN** prompt.
12. Enter the **SUPRVSN TIME** and press **CMD**.
13. At **DISARM DISABLE**, select **NO** or **YES**.
14. At the **NEXT ZN?** prompt, select **YES** to finish programming or select **NO** for additional programming options.

2 INSTALL THE BATTERY

Use a 3.0V lithium battery, a DMP Model CR123 battery, or an equivalent model from Sony or Murata. For listed installations, use either an Energizer® 123 battery or a CR123A battery manufactured by Panasonic or Tekcell. Keep in mind, when setting up a wireless system, program zones and connect the wireless receiver before installing the battery.

1. Open the 1106 by inserting a 1/4" flat head screwdriver in the tab. See Figure 1.
2. Gently pull upwards on the screwdriver handle until the housing completely opens.
3. Observe polarity and place the battery in the holder and press it into place.

3

SELECT A LOCATION

The 1106 provides a Survey LED capability to allow one person to confirm communication with the wireless receiver or panel while the cover is removed.

1. Hold the 1106 in the exact desired location.
 2. Press the tamper switch to send data to the panel and determine if communication is confirmed or faulty.
- ✓ **Confirmed:** If communication is confirmed, for each press or release of the tamper switch the LED blinks immediately on and immediately off. Repeat this test to confirm five separate consecutive LED blinks. Any indication otherwise means proper communication has not been established.
- ✗ **Faulty:** If communication is faulty, the LED remains on for about 8 seconds or flashes multiple times in quick succession. Relocate the 1106 or wireless receiver until the LED confirms clear communication.

4

MOUNT THE 1106

For ETL listed and commercial installations, use the supplied screws when mounting the transmitter and the magnet.

Mount the Transmitter

1. If mounting with screws, remove the battery. If mounting with double-sided tape, place the tape on the back of the transmitter.
2. Hold the transmitter in place with the magnetic reed switch closest to where the magnet will be mounted. See Figure 2. Ensure the transmitter and the magnet will be no more than 1/2" (1.3cm) apart.
3. If using screws, place the supplied #4 screws into the two mounting holes and secure the transmitter to the surface. If using double-sided tape, place the transmitter on the surface.
4. Snap the transmitter cover back onto the base.

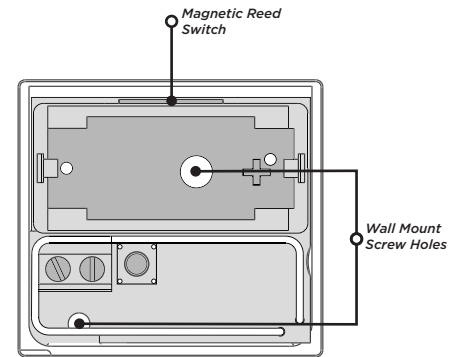

Figure 2: Transmitter Components

Mount the Magnet

Standard Installation

1. Push the supplied magnet into the magnet cover.
2. Hold the magnet base on the door closest to the magnetic reed switch, no more than 1.3cm (0.5in) from the transmitter.
3. If using screws, use the provided #4 screws to mount the base. See Figure 3. If using double-sided tape, place the tape on the back of the base and place on the surface.
4. Snap the cover onto the base.

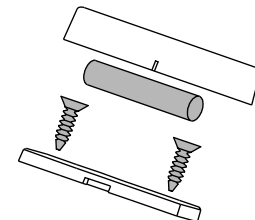

Figure 3: Standard Installation

Commercial Installation

1. Push the supplied magnet into the magnet cover.
2. Place and hold the magnet cover directly on the door closest to the magnetic reed switch, no more than 1.3cm (1.5in) apart from the transmitter.
3. Use the provided #4 screws to mount the cover. See Figure 4.

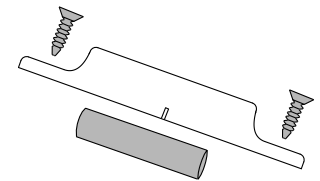

Figure 4: Commercial Installation

5

TEST THE 1106

After installing the 1106, perform a Walk Test to confirm the 1106 is communicating with the panel. At the keypad, enter **8144** (WALK) and select **WLS**. If the 1106 fails to check in at the keypad, relocate the wireless device, receiver, or panel.

ADDITIONAL INFORMATION

Connect External Contacts

Refer to *Contacts* and *Zone Information* in the appropriate panel programming guide for more information. DMP recommends using 18 or 22 AWG un-shielded wire. If you use both the magnet reed switch in the 1106 transmitter and an external contact, use consecutive zone numbers when connecting them to the panel.

1. Remove the cover of the 1106.
2. Use a flat head screwdriver to loosen the two screws on the 1106 terminal block. See Figure 5.
3. Insert the external contact wiring into the 1106 terminal block and tighten the screws.
4. Depending on how the contact was programmed in the *Program the Panel* section, connect the other ends of the wires to the external contact as either normally open (N/O) or normally closed (N/C) without an end-of-line resistor.

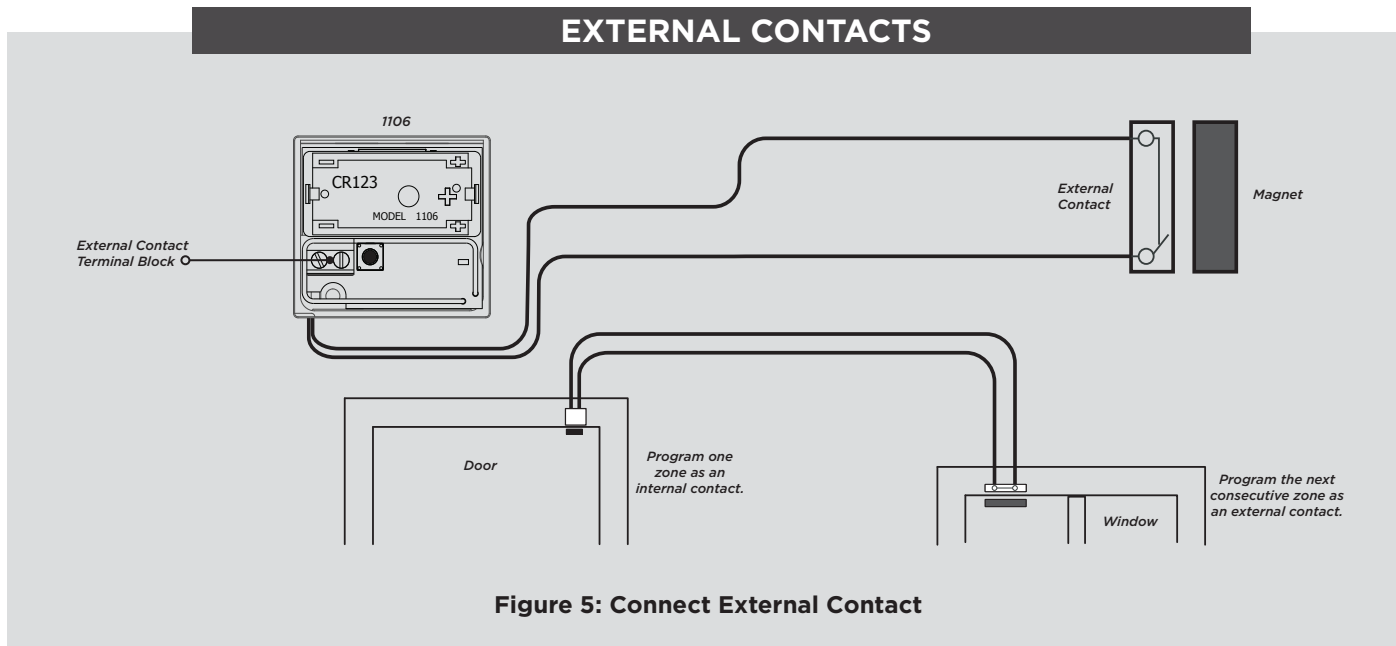

Replace the Battery

1. Open the transmitter housing to expose the inside of the 1106. See Figure 1.
2. Remove the old battery, observe polarity, and place the new battery in the holder.
3. Snap the cover back on the 1106.

Sensor Reset to Clear LOBAT

Once the battery is replaced, a sensor reset is required at the keypad to clear the **LOBAT** message.

1. On an LCD Keypad, press and hold **2** for two seconds. On a Graphic Touchscreen Keypad, press **RESET**.
2. Enter your user code, if required. The keypad displays **SENSORS OFF** followed by **SENSORS ON**.

FCC INFORMATION

This device complies with Part 15 of the FCC Rules. Operation is subject to the following two conditions:

1. This device may not cause harmful interference, and
2. This device must accept any interference received, including interference that may cause undesired operation.

The antenna used for this transmitter must be installed to provide a separation distance of at least 20 cm (7.874 in.) from all persons. It must not be located or operated in conjunction with any other antenna or transmitter.

Changes or modifications made by the user and not expressly approved by the party responsible for compliance could void the user's authority to operate the equipment.

 **Note:** This equipment has been tested and found to comply with the limits for a Class B digital device, pursuant to part 15 of the FCC Rules. These limits are designed to provide reasonable protection against harmful interference in a residential installation. This equipment generates, uses and can radiate radio frequency energy and, if not installed and used in accordance with the instructions, may cause harmful interference to radio communications. However, there is no guarantee that interference will not occur in a particular installation. If this equipment does cause harmful interference to radio or television reception, which can be determined by turning the equipment off and on, the user is encouraged to try to correct the interference by one or more of the following measures:

- Reorient or relocate the receiving antenna.
- Increase the separation between the equipment and receiver.
- Connect the equipment into an outlet on a circuit different from that to which the receiver is connected.
- Consult the dealer or an experienced radio/TV technician for help.

INDUSTRY CANADA INFORMATION

This device complies with Industry Canada Licence-exempt RSS standard(s). Operation is subject to the following two conditions:

1. This device may not cause interference, and
2. this device must accept any interference, including interference that may cause undesired operation of the device.

This system has been evaluated for RF Exposure per RSS-102 and is in compliance with the limits specified by Health Canada Safety Code 6. The system must be installed at a minimum separation distance from the antenna to a general bystander of 7.87 inches (20 cm) to maintain compliance with the General Population limits.

Le présent appareil est conforme aux CNR d'Industrie Canada applicables aux appareils radio exempts de licence. L'exploitation est autorisée aux deux conditions suivantes:

1. *l'appareil ne doit pas produire de brouillage, et*
2. *l'utilisateur de l'appareil doit accepter tout brouillage radioélectrique subi, même si le brouillage est susceptible d'en compromettre le fonctionnement.*

L'exposition aux radiofréquences de ce système a été évaluée selon la norme RSS-102 et est jugée conforme aux limites établies par le Code de sécurité 6 de Santé Canada. Le système doit être installé à une distance minimale de 7,87 pouces (20 cm) séparant l'antenne d'une personne présente en conformité avec les limites permises d'exposition du grand public.

1106 Series Wireless Universal Transmitter

Specifications

Battery

Life Expectancy	5 years (normal operation)
Type	3.0V lithium CR123A

Frequency Range 905-924 MHz

Color White

Housing Material Flame retardant ABS

Dimensions

Transmitter Case	1.79"L x 1.69"W x 0.84"H
Standard Magnet Housing	1.35"L x 0.38"W x 0.43"H
Commercial Magnet Housing	2.25"L x 0.38"W x 0.34"H

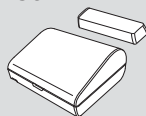

Patents

U. S. Patent No. 7,239,236

Ordering Information

1106-W Standard Wireless Universal Transmitter
1106E-W Encrypted Wireless Universal Transmitter

Certifications

FCC Part 15 Registration ID: CCKPC0124

Industry Canada: 5251A-PC0124

ETL Listed

- ANSI/UL 1023 Household Burglar Alarm System
- ANSI/UL 634 Connections and Switches for use with Burglar Alarm Systems Accessory

Universal Specifications

Do not use double-sided tape for listed installations.

Household Burglar Alarm System Units ANSI/UL 1023

Install only on non-conductive surfaces.



Designed, engineered,
and manufactured in
Springfield, Missouri using U.S.
and global components.

LT-1377 1.01 20164

INTRUSION • FIRE • ACCESS • NETWORKS

2500 North Partnership Boulevard
Springfield, Missouri 65803-8877

866.266.2826 | DMP.com