

1131 WIRELESS RECESSED CONTACT

Installation Guide

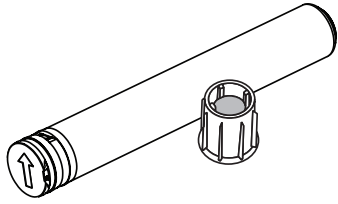

Figure 1: 1131 Recessed Contact

DESCRIPTION

The 1131 is a wireless recessed contact that provides concealed protection for doors, windows, or any other application needing a discreet contact. As with all DMP 1100 Series transmitters, the onboard LED provides built-in survey capability to allow for single-person installations, eliminating the requirement for an external survey kit. The 1131 transmits Normal, Alarm, and Low Battery conditions.

Compatibility

- All 1100 Series Wireless Receivers and panels with built-in 1100 Series Wireless Receivers

What is Included?

- One 1131 Transmitter
- One 1131MAG-W Magnet
- One 3 V Lithium CR12600 Battery



1 PROGRAM THE PANEL

Refer to the panel programming guide as needed. After completing each of the following steps, press **CMD** to advance to the next prompt.

1. At a keypad, enter **6653** (PROG) to access the Programmer Menu.
2. At **ZONE INFORMATION**, enter the wireless zone number.
3. At ***UNUSED***, enter the zone name.
4. At **ZONE TYPE**, press any select key or area and select the zone type.
5. At **AREA NO**, enter the area number.
6. At the **NEXT ZN?** prompt, select **NO**.
7. When **WIRELESS?** displays, select **YES**.
8. At **SERIAL#**, enter the eight-digit device serial number.
9. At **SUPRVSN TIME**, enter a supervision time. Default is **240**.
10. At the **NEXT ZN?** prompt, select **YES** if you are finished programming the zone. Select **NO** if you would like to access additional programming options.
11. To save panel programming, go to **STOP** and press **CMD**.

2 INSTALL THE BATTERY

Use only 3.0 V lithium batteries, such as the Model CR12600.

1. Insert a small screwdriver in the hole at the bottom of the housing tube to push out the battery tray and PCB.
2. Place the battery back into the battery tray with the negative end of the battery facing the transmitter PCB.
3. Slide the battery tray and PCB into the housing tube as required for desired travel distance. Refer to Figure 2.

Travel Distance

Depending on PCB orientation, the distance that the door can travel before a fault is indicated can be increased or decreased. For areas where wood doors expand and contract seasonally, it may be helpful to increase travel distance.

 **Note:** The travel distance of sliding doors is 3/4" regardless of the reed switch orientation.

3/4 Inch Travel Distance—Install the transmitter with the reed switch on the top side of the PCB to allow a longer (3/4") distance of travel.

3/8 Inch Travel Distance—Install the transmitter with the reed switch on the bottom side of the PCB to allow a shorter (3/8") distance of travel.

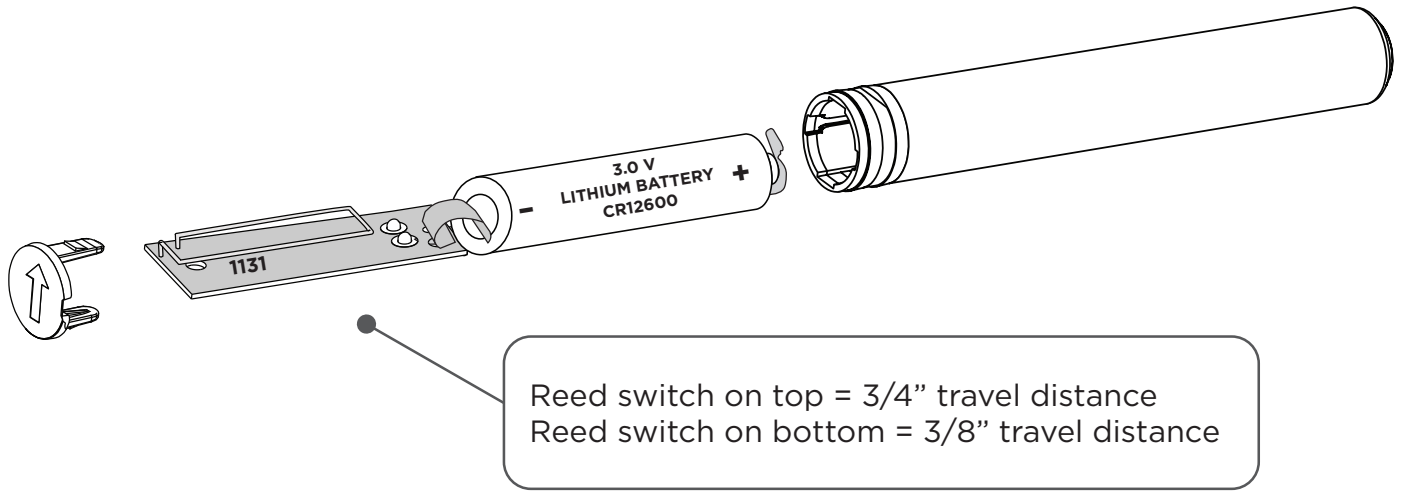

Figure 2: Assembling the Housing

3 SELECT A LOCATION

The 1131 provides a Survey LED capability to allow one person to confirm communication with the wireless receiver or panel while the cover is removed.

1. Move the magnet within 1/2 inch of the contact or pull it away from the contact to send data to the receiver.
 - ✓ **Confirmed:** If communication is confirmed, the LED blinks once, immediately on and immediately off. Repeat this test to confirm five separate consecutive LED blinks. Any indication otherwise means proper communication has not been established. Repeat this test to confirm five separate consecutive LED blinks. Any indication otherwise means proper communication has not been established.
 - ✗ **Faulty:** If communication is faulty, the LED remains on for about 8 seconds or flashes multiple times in quick succession. Relocate the contact or receiver until the LED confirms clear communication.

For contact operation, the transmitter and magnet assembly should have no more than 1/2" between the housings after installation. When mounting on metal (ferrous) surfaces, this distance is slightly less. For door installations, it is recommended the transmitter be mounted in the door frame and the magnet assembly be mounted in the door. If the transmitter is installed in a metal door frame, the communication distance to the receiver may be reduced.

4 MOUNT THE TRANSMITTER AND CONTACT

1. To install the transmitter, use a 5/8" spade drill bit and drill a hole at least 4 3/4" deep in the frame at the desired location.
 - ⚡ **Caution:** Avoid drilling in areas where electrical wiring runs through the wall.
2. Insert the transmitter housing into the hole until the cap is flush with the door jamb. Refer to Figure 3.
3. To install the magnet, use a 5/8" spade drill bit, drill a hole at least 3/4" deep in the frame at the desired location.
4. Insert the magnet into the hole and press it into place.

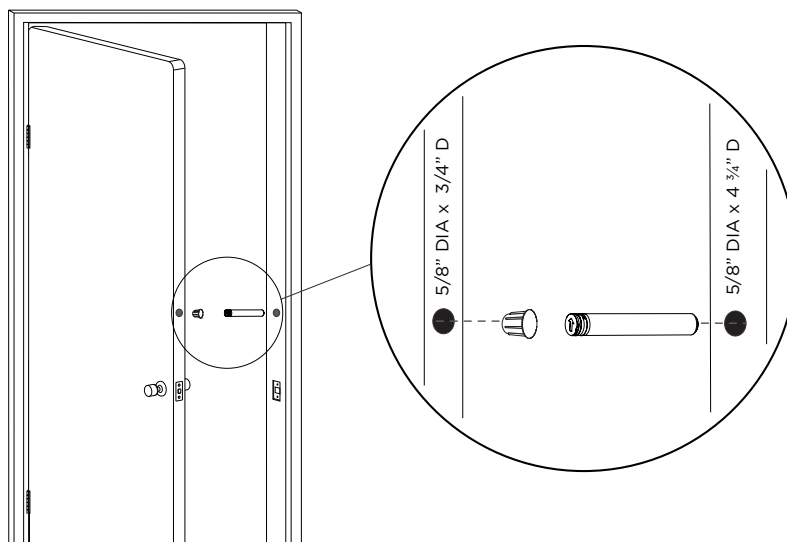

Figure 3: Mounting the Transmitter and Magnet

5 TEST THE TRANSMITTER

After the transmitter has been installed, test to confirm that it is communicating reliably with the panel. Use the Tech APP™ to perform a Wireless Walk Test on the system or complete the following steps to perform a Walk Test from a keypad that is connected to the panel:

At the keypad, enter **8144** (WALK) and select WLS. If the transmitter fails to check in at the keypad, ensure that it is wired properly and check for sources of interference such as metal objects and electronic equipment.

ADDITIONAL INFORMATION

Supervision Time

When a receiver is installed, powered up, or the panel is reset, the supervision time for transmitters is reset. If the receiver has been powered down for more than one hour, wireless transmitters may take up to an additional hour to send a supervision message unless tripped, tampered, or powered up. This operation extends battery life for transmitters. A missing message may display on the keypad until the transmitter sends a supervision message.

Replace the Battery

To replace the battery, complete the following steps.

1. To remove the transmitter cap, inserting a small flathead screwdriver into the cap notch and gently pry it away from the transmitter housing. Refer to Figure 4.
2. Slide the transmitter and battery assembly from the housing tube. Gently pull while gripping the antenna and end of the printed circuit board with your fingers.
3. Remove the old battery and dispose of it properly.
4. Place the 3.0 V lithium battery in the holder as shown in Figure 2.
5. Slide the transmitter and battery assembly into the transmitter housing.
6. Install the cap on the transmitter housing tube with the arrow facing up.

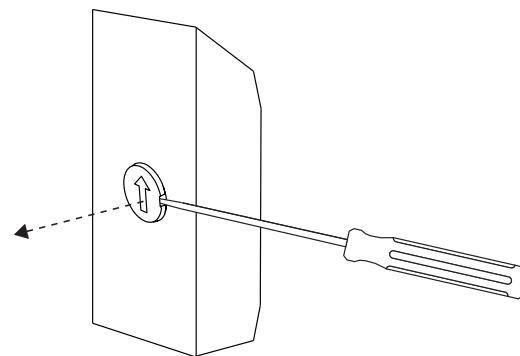

Figure 4: Removing the Transmitter Cap

Sensor Reset to Clear LOBAT

1. Once the battery is replaced, a sensor reset is required at the keypad to clear the **LOBAT** message.
2. On an LCD keypad, press and hold 2 for two seconds. On a graphic touchscreen keypad, press **RESET**. Enter your user code, if required. The keypad displays **SENSORS OFF** followed by **SENSORS ON**.

FCC INFORMATION

This device complies with Part 15 of the FCC Rules. Operation is subject to the following two conditions:

1. This device may not cause harmful interference, and
2. this device must accept any interference received, including interference that may cause undesired operation.

The antenna used for this transmitter must be installed to provide a separation distance of at least 20 cm (7.874 in.) from all persons. It must not be located or operated in conjunction with any other antenna or transmitter.

Changes or modifications made by the user and not expressly approved by the party responsible for compliance could void the user's authority to operate the equipment.

 **Note:** This equipment has been tested and found to comply with the limits for a Class B digital device, pursuant to part 15 of the FCC Rules. These limits are designed to provide reasonable protection against harmful interference in a residential installation. This equipment generates, uses and can radiate radio frequency energy and, if not installed and used in accordance with the instructions, may cause harmful interference to radio communications. However, there is no guarantee that interference will not occur in a particular installation. If this equipment does cause harmful interference to radio or television reception, which can be determined by turning the equipment off and on, the user is encouraged to try to correct the interference by one or more of the following measures:

1. Reorient or relocate the receiving antenna.
2. Increase the separation between the equipment and receiver.
3. Connect the equipment into an outlet on a circuit different from that to which the receiver is connected.
4. Consult the dealer or an experienced radio/TV technician for help.

INDUSTRY CANADA INFORMATION

This device complies with Industry Canada Licence-exempt RSS standards. Operation is subject to the following two conditions:

1. This device may not cause interference, and
2. this device must accept any interference, including interference that may cause undesired operation of the device.

This system has been evaluated for RF Exposure per RSS-102 and is in compliance with the limits specified by Health Canada Safety Code 6. The system must be installed at a minimum separation distance from the antenna to a general bystander of 7.87 inches (20 cm) to maintain compliance with the General Population limits.

Le présent appareil est conforme aux CNR d'Industrie Canada applicables aux appareils radio exempts de licence. L'exploitation est autorisée aux deux conditions suivantes:

1. *l'appareil ne doit pas produire de brouillage, et*
2. *l'utilisateur de l'appareil doit accepter tout brouillage radioélectrique subi, même si le brouillage est susceptible d'en compromettre le fonctionnement.*

L'exposition aux radiofréquences de ce système a été évaluée selon la norme RSS-102 et est jugée conforme aux limites établies par le Code de sécurité 6 de Santé Canada. Le système doit être installé à une distance minimale de 7,87 pouces (20 cm) séparant l'antenne d'une personne présente en conformité avec les limites permises d'exposition du grand public.

1131 WIRELESS RECESSED CONTACT

Specifications

Battery	
Life Expectancy	5 years (normal operation)
Type	3.0 V lithium CR12600
Frequency Range	905-924 MHz
Dimensions	
Transmitter Housing	4.175" L x 0.55" DIA 10.60 cm L x 1.40 cm DIA
Magnet Housing	0.7" L x 0.55" DIA 1.78 cm L x 1.40 cm DIA
Housing Material	Flame retardant ABS

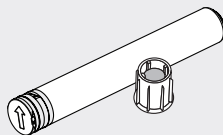

Ordering Information

1131-W Wireless Recessed Contact, white

Accessories

CR12600/8 Replacement battery, 8 pack
1131MAG-W/10 Magnet in Housing, 10 pack

Compatibility

All 1100 Series Wireless Receivers
All Panels with Built-In 1100 Series Wireless Receivers

Patents

U. S. Patent No. 7,239,236

Certifications

FCC Part 15 Registration ID CCKPC0191
Industry Canada Registration ID 5251A-PC0191



Designed, engineered, and
manufactured in Springfield, MO
using U.S. and global components.

LT-0976 20164

© 2020

INTRUSION • FIRE • ACCESS • NETWORKS

2500 North Partnership Boulevard
Springfield, Missouri 65803-8877

800.641.4282 | DMP.com