

# MODEL 505-12L/505-12A POWER SUPPLY

## WIRING DIAGRAM

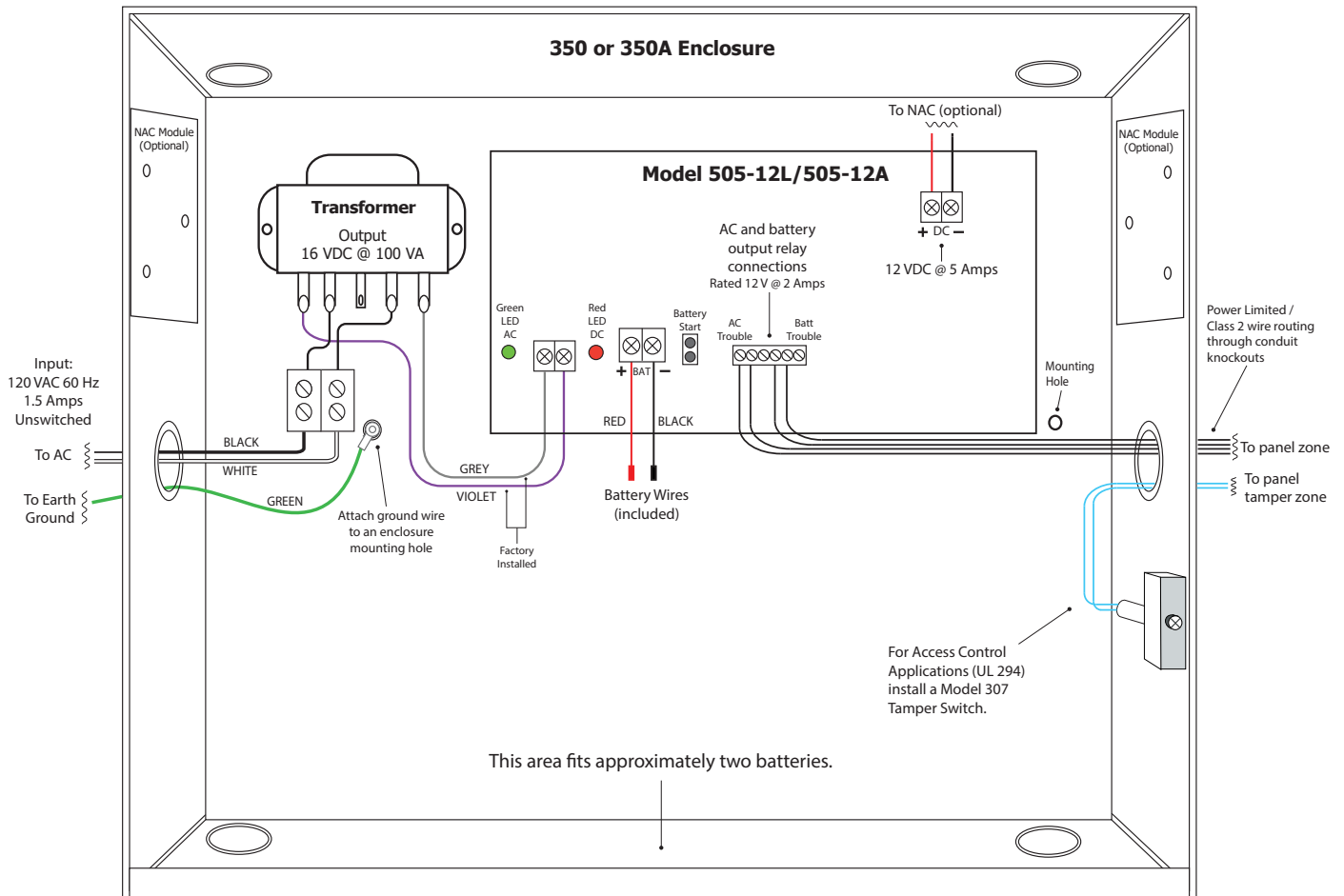

Output Current								
Input Voltage	Input Voltage Type	Output Voltage	Output Voltage Type	Normal Standby	Standby Battery Min Operating Time	Maximum (Alarm)	Standby Battery Operating Time	Ripple Voltage
120 VAC	Alternating Current	12 VDC	Direct Current	1.25 Amps	24 Hours	5.0 Amps	5 Minutes	350 mV

Refer to the 505 Series Power Supply Installation Guide (LT-0453) for complete descriptions of wiring connections, battery installation, and NAC Module information.

For UL Listed Fire Protective Signaling Systems, use only with XR150/XR550 Series panels. For special applications, refer to the specific panel installation guide for a list of compatible fire notification appliances.

### Specifications

12 VDC Power Supply      5 Amp Maximum  
 For UL 603 and UL 294      10.76-12.36 VDC at 1.25 Amps normal standby and 5 Amps alarm

**Note:** Not intended to provide power for sounding devices in UL 609 Local Burglar System

### Secondary Power Supply

1.5 Amps maximum charge current. Use only 12 VDC batteries. Replace every 3-5 years.

### Power Limited

All circuits in the Model 505 comply with the requirements for inherent power limitation and are Class 2 with exception of the red battery wire.

### NFPA

This equipment should be installed in accordance with the Standard Fire-Protective Signaling Service (National Fire Protection Association, Batterymarch Park, Quincy MA 02269)

### Certifications

UL 1481      Power Supplies for Fire Protective Signaling Systems  
 UL 603      Power Supplies for Burglary Alarm Systems  
 UL 294      Power Supplies for Access Control System Units