

1139-WINT Bill Trap Transmitter

Description

The 1139-WINT Bill Trap is a wireless transmitter designed to provide a silent alarm in retail and banking cash drawers by trapping one bill below a stack of bills. When the trapped bill is removed, a panic alarm is sent. To reduce the possibility of a false alarm, a delay can be programmed to provide time to replace the bill should it be accidentally removed.

Compatibility

1100 Series International Wireless Receivers

What is Included

The 1139-WINT Bill Trap Transmitter includes the following items:

- One Bill Trap with DMP wireless transmitter installed
- Two CR2450 3V lithium coin cell batteries
- Velcro mounting strip
- Zone name and number label
- Serial number label

Transmitter Serial Number

For your convenience, an additional pre-printed serial number label is included. Record the serial number or place the pre-printed serial number label on the panel programming sheet. This number is required during programming. As needed, use the zone name and number label to identify a specific transmitter.

Programming the Bill Trap in the Panel

Refer to the panel programming guide as needed. Program the device as a zone in **Zone Information** during panel programming. At the Serial Number prompt, enter the 8-digit serial number. Continue to program the zone as directed in the panel programming guide.

Note: When a receiver is installed, powered up, or the panel is reset, the supervision time for transmitters is reset. If the receiver has been powered down for more than 1 hour, wireless transmitters may take up to an additional hour to send a supervision message unless tripped, tampered, or powered up. This operation extends battery life for transmitters. A missing message may display on the keypad until the transmitter sends a supervision message.

Application Example

When using an 1139-WINT Bill Trap, program the zone as a Panic type zone. XR150INT/XR550INT International Series panels provide a Retard Delay that can be programmed on Panic type zones. In System Options set a Retard Delay time from 1 to 250 seconds. This provides time to replace an accidentally removed bill and avoid a false alarm. Also, an output can be assigned to the zone with the action set to Follow. When connected to a preprogrammed DVR and camera, and the panic zone is tripped, the camera can increase the frame speed.

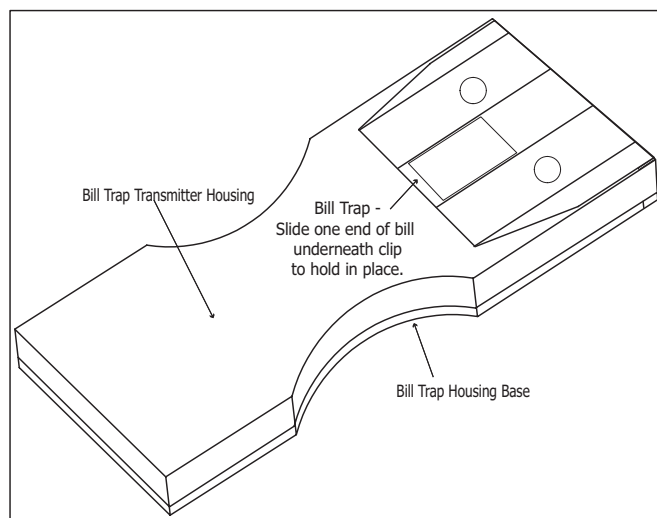

Figure 1: 1139-WINT Bill Trap

Selecting the Proper Location (LED Survey Operation)

Note: Refer to Figure 2 to remove the 1139-WINT housing base and Figure 3 for the 1139-WINT PCB LED and tamper switch locations.

The 1139-WINT Bill Trap provides a survey capability to allow one person to confirm transmitter communication with the receiver while the cover is removed. The 1139-WINT Bill Trap PCB Red Survey LED turns on whenever data is sent to the receiver then immediately turns off when the receiver acknowledgement is received. Pressing the tamper switch is a convenient way to send data to the receiver to confirm operation. When the tamper switch is pressed or released, the LED blinks once to indicate proper operation. When the transmitter does not receive an acknowledgement from the receiver the LED remains on for about 8 seconds or flashes multiple times in quick succession to let you know communication is not established. Relocate the transmitter or receiver until the LED immediately turns off indicating the transmitter and receiver are communicating properly. Proper communication between the transmitter and receiver is verified when for each press or release of the tamper switch, the LED blinks immediately on and immediately off. Repeat this test to confirm five separate consecutive LED blinks. Any indication otherwise means proper communication has not been established.

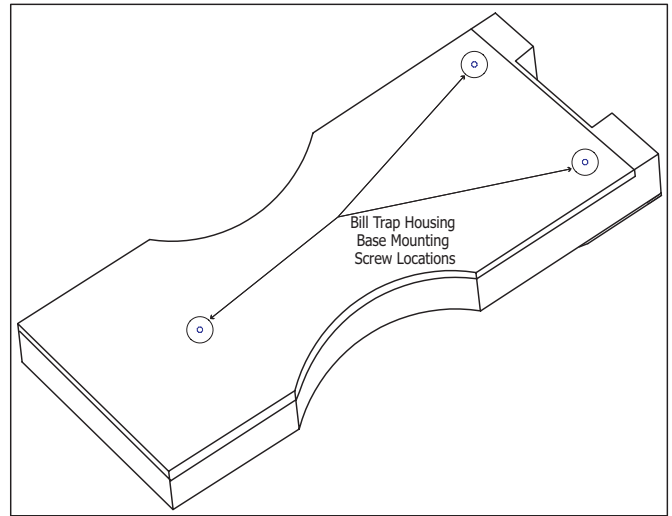

Figure 2: Bill Trap Base and Mounting Screw Locations

Installing the Bill Trap

Slide a bill into the Bill Trap on the 1139-WINT as shown in Figure 1. The 1139-WINT Bill Trap unit easily slides into a bill slot of a cash drawer. Place additional bills above the trapped bill for standard cash drawer operation.

Installing or Replacing the Battery

Observe polarity when installing the battery. Use only 3V lithium batteries, DMP Model CR2450, or the equivalent battery from a local retail outlet.

Note: When setting up a wireless system, it is recommended to program zones and connect the receiver before installing batteries in the transmitters.

To install or replace batteries or access the tamper switch and view the LED flash:

1. Use a Phillips screwdriver to remove the three screws holding the base and housing together. See Figure 2.
2. Gently lift the PCB out of the housing.
3. If installed, push and slide each old battery out of the holder in the direction of the arrow to remove it. See Figure 3.
4. Verify the positive side of the new battery is up.
5. Slide each new 3V lithium battery into its holder and push into place.

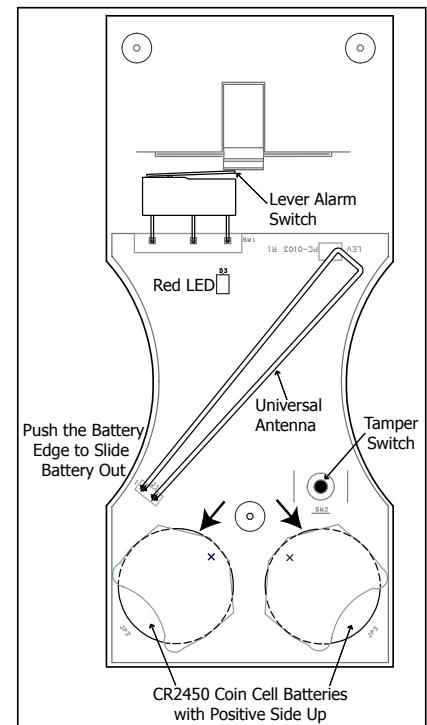

Figure 3: Bill Trap Battery Locations

6. Gently slide the PCB back into the housing making sure the lever alarm switch is in position to activate.
See Figure 4.

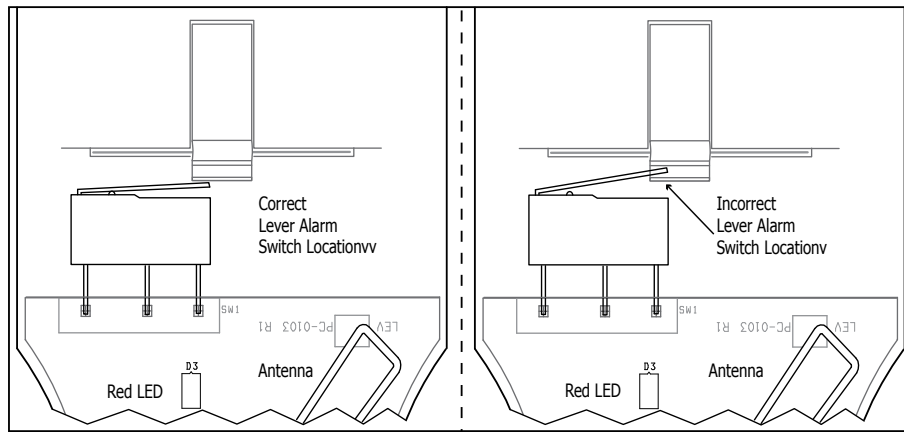

Figure 4: Lever Alarm Switch Location Detail

7. Use a Phillips screwdriver to replace the base onto the housing.
8. Slide the bill trap back into the cash drawer.



Caution: Properly dispose of used batteries. Do not recharge, disassemble, heat above 212°F (100°C), or incinerate. Risk of fire, explosion, and burns.

Battery Life Expectancy

Typical battery life expectancy for DMP Model 1139-WINT Bill Trap is 1 year, using 2 batteries. DMP wireless equipment uses two-way communication to extend battery life.

The following situations can reduce battery life expectancy:

- If a receiver is unplugged, too far away, or not installed.
Note: Transmitters continue to send supervision messages until a receiver returns an acknowledgement.
- Frequent transmissions, such as constant removing and replacing the trapped bill.
- When installed in extreme hot or cold environments.

The following situation can extend battery life expectancy:

- Extend transmitter supervision time in panel programming.
- Infrequent transmission trips.

Specifications

Battery

Life Expectancy 1 year using 2 batteries
Type 3V lithium CR2450
See Battery Life Expectancy for details.

Frequency Range 863-869 MHz
Transmit condition Alarm, Tamper
Dimensions 5.375" H x 2.625" W x .625" D
13.7 H x 6.7 W x 1.6 D cm

Color Ivory
Housing material Flame retardant ABS

Patents

U. S. Patent No. 7,239,236

Compatibility

1100X-WINT Wireless Receiver
1100D-WINT Wireless Receiver
XT30INT Series panel
XR150INT/XR550INT Series panels

International Certifications

EN 61000-6-3 EMC Generic Standards - Emission standard for Residential, Commercial and Light-industrial Environments
EN 50130-4 EMC Product Family Standard: Immunity Requirements For Components of Fire, Intruder and Social Alarm Systems



800-641-4282

www.dmp.com

Designed, Engineered and
Assembled in U.S.A.

INTRUSION • FIRE • ACCESS • NETWORKS

2500 North Partnership Boulevard

Springfield, Missouri 65803-8877

