

1.1 Introduction

The 891/891A Programming Manual provides programming information for the DMP 1512 and 1912 Command Processor panels. Individual technical specifications for either panel can be found in the *1512 Installation Guide* (LT-0138) and the *1912 Installation Guide* (LT-0127). This manual details the operation of the 891A Programmer using firmware level 101 or higher.

The 891/891A is not for use with other DMP command processor panels.

Begin your panel programming in section 2 - **Initialization**. The options in section 2 allow you to clear the panel's memory before programming.

The 891 Programmer provides functions described in sections 2 to 14. The 891/891A Programmer provides the same functions *plus* sections 15 to 17. The programming functions in this manual follow the order of programming using the 891/891A.

Included with each panel is a programming information sheet that lists the available programming options. Before starting to program, we recommend you completely fill out this sheet. A completed programming sheet helps prevent errors and provides an accurate account of the panel's program. When you're finished programming, keep the information sheet on file to provide a record of the system.

Read the remainder of this introduction before starting to program for information on how to start and end a programming session with the 891/891A Programmer.

1.2 Programmer Installation

The 1512 and 1912 Command Processor panels must be completely installed and grounded before you begin programming.

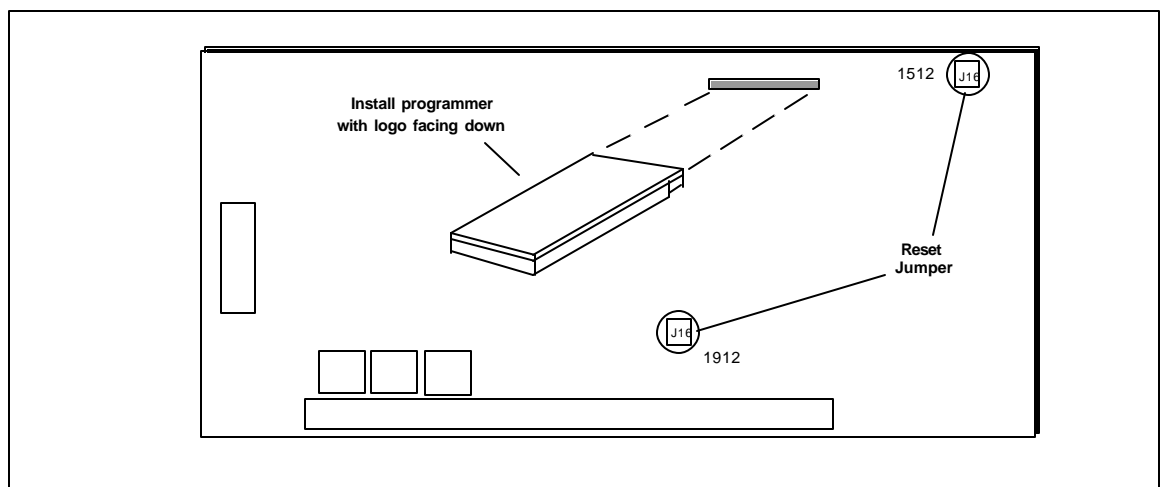

Figure 1: Connecting the programmer to the panel

Touch a grounded surface to prevent ESD: Electrostatic discharges can damage the panel and programmer. Always touch a grounded surface before handling any electronic equipment.

1. Install the J16 reset jumper on the command processor panel.
2. Apply power to the panel.
3. Install the programmer with the DMP logo face down.
4. Remove the J16 reset jumper to begin programming.

Always install J16 before installing or removing the programmer.

All programming is done through security command keypad address number one. If you're programming a panel that does not have a keypad for address one, or if the address one keypad is a non-alpha keypad, use another keypad set to address zero. While programming with a keypad set for address zero, you cannot program from address one. Select address zero by placing all switches on the switchblock inside the keypad in the down position.

1.3 Programmer Operation

With the programmer installed and operating, security command address number one displays the current firmware level of the programmer and the firmware level of the panel.

[PR: XXXX PNL: YYYY]

XXXX = The firmware level of the programmer

YYYY = The firmware level of the panel

By pressing the COMMAND key, the display advances through the programming menu. There are 16 programming sections to choose from:

	Section		
Initialization	2		
Communication	3		
Control Setup	4		
Remote Options	5		
Set System Number	6		
System Reports	7		
System Options	8		
Output Options	9		
Menu Display	10		
Status List	11		
Area Information	12		
Loop Information	13		
Stop	14		
Save Into 891/891A	15	YES	Available with the 891A only
Load Into Panel	16	YES	
Compute Checksum	17	YES	

To select a section for programming, press any one of the top row select keys when the name of that section is displayed on the keypad. The detailed instructions for each programming step are found in sections 2 to 17 of this manual.

1.4 Special Keys

COMMAND

The COMMAND key is used to step ahead in programming. Pressing the COMMAND key allows you to go forward through the programming menu and through each step of a programming section. As you go through the programming, the keypad display shows any current programming already stored in the panel's memory.

If the information is not to be changed, press the COMMAND key to advance to the next step.

The COMMAND key is also used to enter information into the panel's memory such as phone numbers or loop names. Press the COMMAND key after you've entered the information and it is displayed correctly on the keypad.

1.4 Special Keys continued



Use the back **arrow** key to back up one step while in the programming menu or within a programming section.

The back arrow key is also used when an error is made while entering information. Press the back arrow key once to erase the last character entered.



The top row of keys are called the **select** keys. Each time a select key is to be used, the keypad displays the function above the key. Displaying functions above the individual select keys allows them to be used for many different applications. For example, you can enter AM or PM when programming the automatic recall time or answer YES or NO for a system option.

During programming, the select keys also allow you to change information currently in the panel's memory. As you step through each program option, the keypad displays the current information. To change this information, press the appropriate key under the display then enter the new information through the keypad.

If you are changing a phone number or account number, press the appropriate digit keys. If entering a communication type or a YES to a programming option, the keypad displays the available response options above the select keys. When there are more than four response options available, the keypad displays the first four. Pressing the COMMAND key brings up the next 1 to 4 options on the display. Pressing the arrow key allows you to review the previous four choices.

The select keys are also used for selecting a section from the programming menu. This is done by pressing any one of the select keys when the name of the programming section you want is displayed.

1.5 Entering Alpha Characters

Some options during programming require you to enter alpha characters. To enter an alpha character, press the key that has that letter written below it. The keypad displays the number digit of the key. Then press the top row select key that corresponds to the location of the letter under the key. Pressing a different select key changes the letter. When another digit key is pressed, the last letter displayed is retained and the process is started over.

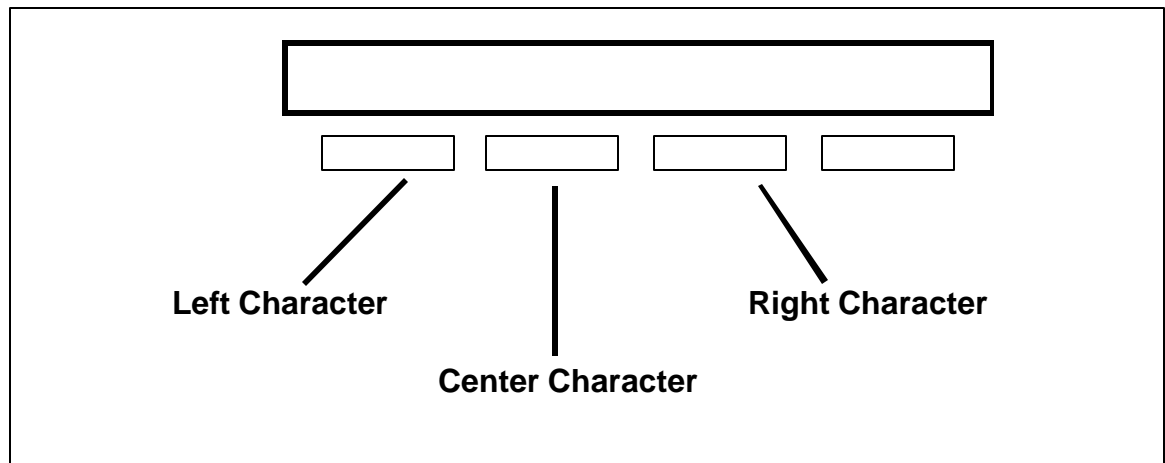

Figure 2: Keypad display and top row keys

1.6 Entering Spaces With Alpha Characters

To enter a space in an alpha entry, press the 9 digit key followed by the third select key. The three characters on the 9 digit key are Y, Z, and space.

2.1 Initialization

This function allows you to clear selected parts of the panel's memory in preparation for system programming. There are seven sections of the memory you can clear:

	Reference
User Codes	2.2
Schedules	2.3
Display Events	2.4
Loop Information	2.5
Area Information	2.6
Communication and Remote Options	2.7
System Information	2.8

After you select YES to clear a section of memory the panel asks if you are sure you want to clear the memory. This is a safeguard against accidentally erasing part of your programming. No memory is cleared until you answer YES to the SURE? question.

A description of each selection follows:

- | | | | | |
|------------|------------------|------------|-------------|--|
| 2.2 | [CODES? | NO | YES] | CLEAR ALL CODES - YES clears the user code memory and enters the user code number 99 into the last user position with access to all areas. |
| | [SURE? | YES | NO] | |
| 2.3 | [SCHEDS? | NO | YES] | CLEAR ALL SCHEDULES - YES clears all output, temporary and permanent schedules. |
| | [SURE? | YES | NO] | |
| 2.4 | [EVENTS? | NO | YES] | CLEAR DISPLAY EVENTS MEMORY - YES clears the display events memory. |
| | [SURE? | YES | NO] | |
| 2.5 | [LOOPS? | NO | YES] | CLEAR LOOP INFORMATION - YES clears the loop information for all loops. All loops are marked * UNUSED *. |
| | [SURE? | YES | NO] | |
| 2.6 | [AREAS? | NO | YES] | CLEAR AREA INFORMATION - YES clears the area information for all areas. All areas are marked * UNUSED *. |
| | [SURE? | YES | NO] | |
| 2.7 | [COM/RMT? | NO | YES] | CLEAR COMMUNICATION AND REMOTE OPTIONS - YES clears the communication and remote options programming to factory presets. |
| | [SURE? | YES | NO] | |
| 2.8 | [SYSTEMS? | NO | YES] | CLEAR SYSTEM INFORMATION - YES clears the options in control setup, system reports, system options, output options, menu display, and status lists to factory presets. |
| | [SURE? | YES | NO] | |

3.1 Communication

This program function allows you to enter the communication information needed by the panel. The amount of information needed depends on the type of communication you are using.

- 3.2 [COMM TYPE:]** COMMUNICATION TYPE specifies the type of communication used. The four communication types available are:
- [NONE DD MPX]** NONE - For local systems.
1912 programmer display DD - Dialer communication to a DMP SCS-1 Security Receiver.
- [NONE DD CID]** MPX - Multiplex communication to a DMP SCS-1 Security Receiver. This is
1512 programmer display functional on the 1912 panel only.
CID - Dialer communication to a non-DMP Contact ID receiver.
- 3.3 [BACKUP NO YES]** BACKUP COMMUNICATION allows for the use of a second phone line. This is functional on the 1912 panel only. If backup is YES, use the DMP 893 Dual Line Module for connecting the main and backup phone lines. The panel can be backed up with a second dialer line or multiplex may be backed up with a dialer line. Phone line monitoring is automatically provided by the Model 893.
- Appendix B of this manual fully describes the function of backup communication.

3.4 Additional programming

Additional communication information you must program depends on the type of communication you've specified. Below are section numbers in this manual that contain the remaining programming instructions.

NONE - communication programming complete, no other information required.

DD, CID, or BACKUP as YES - Section 3.6 and 3.7

MPX only - Section 3.5

MPX and BACKUP as YES - Section 3.5 and 3.6B through 3.7

3.5 Multiplex (MPX)

If this is a MPX type communicating system a 5-digit account number is required. A multiplex account number is made up of two parts, the receiver line number it communicates to and the three digit account number of the panel. After you've entered the type of communication in section 3.2, the keypad display shows the current account number held in the panel's memory.

- 3.5A [ACCOUNT NO:]** ACCOUNT NUMBER - The first digit of a multiplex account number is the receiver line number. The second digit is always zero. The last three digits are the control panel's account number. This number must be between the range of 000 and 127.

After you've entered the 5-digit account number for a MPX type system, and NO was selected for backup, the Communication programming terminates. If backup was selected as YES you must also program the information in sections 3.6B to 3.7.

Communication continued

3.6 Digital Dialer (DD) or Contact ID (CID)

For DD and CID type communication, you must enter an account number, two phone numbers, automatic recall information, and dialing parameters. After backup communication has been selected in section 3.3 the display shows the current account number held in the panel's memory.

3.6A [ACCOUNT NO :] ACCOUNT NUMBER - The range of valid account numbers for DD is 1 to 65,535. This is the account number sent to the DMP SCS-1 Receiver.

Contact ID Note: When CID is selected as the communication type and a 5-digit account number is entered, only the last 4 digits are sent to the Contact ID receiver. All 5 digits are sent if the panel communicates to a DMP SCS-1 Receiver used as a backup.

3.6B [FIRST PHONE NO.] FIRST TELEPHONE NUMBER - This is the first number the panel dials when transmitting a report to the receiver. Phone numbers can be up to 15 characters in length. You can program a three second pause in the dialing sequence by entering the letter P. You can program a dial tone detect by entering the letter D. These characters are counted as part of the 15 allowable characters.

[Press COMMAND
enter phone number]

Important: Do not program any letters other than P or D.

Dial tone detect sequence

If you program for dial tone detect, the panel starts dialing as soon as it detects a dial tone. On the first attempt, the panel waits a maximum of five seconds for dial tone. If dial tone is not detected, the module hangs up and tries again. After waiting another five seconds without detecting a dial tone the communication module starts dialing. The panel makes up to ten dialing attempts.

3.6C [SECOND PHONE NO.] SECOND TELEPHONE NUMBER - The panel dials the second number when two successive tries using the first number have failed. If the panel cannot reach the receiver after two attempts using the second number, it returns to the first number and makes two additional attempts. A total of ten dialing attempts are made using the first and second phone numbers. Each number can be up to 15 characters in length and include the P and D characters for pause and dial tone detect.

[Press COMMAND
enter phone number]

Important: Do not program any letters other than P or D.

3.6D [AUTO RCL NO YES] AUTOMATIC RECALL - YES enables an automatic recall report. The recall report is sent according to the schedule defined in sections 3.6E and 3.6F.

3.6E [RECALL DAY:] AUTOMATIC RECALL DAY - You can program the recall report to transmit once each week on a selected day. For daily tests, select all.

3.6F [SUN MON TUE WED] AUTOMATIC RECALL TIME - This is the time the system tests communication to the SCS-1 receiver by transmitting the automatic recall report.
[RECALL TIME? ALL]

[- : AM PM] Example: if you want the new automatic recall time to be 2:45 a.m., press the following keys:

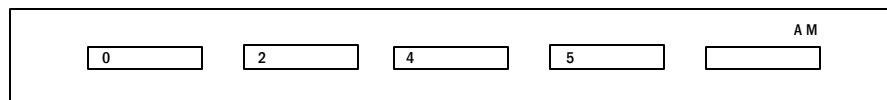

Figure 3: Setting the recall time

Communication continued

3.6G [DTMF NO YES] DTMF - YES enables DTMF dialing. NO enables rotary dialing.

3.6H [EVENT MGR:] EVENTS MANAGER - Specifies when non-alarm reports are transmitted to the receiver. This selection does not affect loop alarm, loop trouble, loop restore, supervisory, or serviceman messages. Closing reports are not affected if you've programmed a YES for the closing wait option. See Section 8.6.

[SND DLY KEEP] SND - If send is selected, all reports are transmitted as they occur.

DLY - If delay is selected, all non-alarm reports are held until the panel's memory buffer contains 66 events, or until the panel's next communication with the receiver.

Immediately	Delayed	Report Type
Y		Alarm
Y		Trouble
Y		Restore
	Y	Opening
	Y	Closing
Y		Bypass
Y		Reset
Y		Supervisory
	Y	Add Codes
	Y	Delete Codes
	Y	Change Codes
	Y	Permanent Schedule Change
	Y	Temporary Schedule Change
	Y	Door Access
Y		Late to Close
Y		Force Armed Loop

Figure 4: Report transmission with Delay enabled

KEEP - All non-alarm reports are held in the panel's memory buffer until they're over written by new activity. You can retrieve the contents of the memory buffer using the DMP Security Information Management System (SIMS) software.

3.7 [2ND RCVR NO YES] SECOND RECEIVER - YES enables reports to be transmitted to a secondary receiver. See [ALL BACKUP] below.

3.7A [2ND TYPE:] SECOND RECEIVER TYPE - Specifies when reports are transmitted to the secondary receiver.

[ALL BACKUP] ALL - Sends all reports to the secondary receiver immediately after they're sent to the main receiver.

BACKUP - Sends only those reports that failed to reach the main receiver to the secondary receiver.

Communication continued

- 3.7B [FIRST PHONE NO.]** FIRST TELEPHONE NUMBER - This is the first number the panel dials when transmitting a report to the receiver. Phone numbers can be up to 15 characters in length. You can program a three second pause in the dialing sequence by entering the letter P. You can program a dial tone detect by entering the letter D. These characters are counted as part of the 15 allowable characters.
- Press COMMAND
[enter phone number]

Important: Do not program any letters other than P or D.

Dial tone detect sequence

If you program for dial tone detect, the panel starts dialing as soon as it detects a dial tone. On the first attempt, the panel waits a maximum of five seconds for dial tone. If dial tone is not detected, the module hangs up and tries again. After waiting another five seconds without detecting a dial tone the communication module starts dialing. The panel makes up to ten dialing attempts.

- 3.7C [SECOND PHONE NO.]** SECOND TELEPHONE NUMBER - The panel dials the second number when two successive tries using the first number have failed. If the panel cannot reach the receiver after two attempts using the second number, it returns to the first number and makes two additional attempts. A total of ten dialing attempts are made using the first and second phone numbers. Each number can be up to 15 characters in length and include the P and D characters for pause and dial tone detect.
- Press COMMAND
[enter phone number]

Important: Do not program any letters other than P or D.

- 3.8 [AUTO RCL NO YES]** SECONDARY AUTOMATIC RECALL - YES enables an automatic recall report to the secondary receiver. The recall report is sent according to the schedule for the main receiver.

4.1 Control Setup

This allows you to define the overall structure of the control panel. This section **MUST** be completed before programming sections 7 to 13. The specific control setup options are:

	Reference
Multisystem	4.2 (Functional on Model 1912)
System Account Numbers	4.3 (Functional on Model 1912)
Device Type	4.4
Device System Assignment	4.5 (Functional on Model 1912)

A description of each option follows:

- 4.2 [MLT SYS? NO YES]** MULTISYSTEM - YES allows the panel to provide up to 4 independently operational systems. Each system can have its own account number, keypad(s), area(s), loops, and options contained in programming sections 7 to 13. The common hardware components of the panel are shared, such as AC power indication, communication format, bell output, and fire reset. An explanation of each panel function and how it is affected by multisystem is given in sections 4.6A to 4.6Y.

Important: Once YES, you cannot change to NO without reinitializing.

- 4.3 [SYS X ACCT:]** SYSTEM ACCOUNT NUMBER - If multisystem is selected as YES, account numbers can be assigned for up to 4 independent systems. This account number is transmitted to the DMP SCS-1 receiver on all system related reports. This option does not appear for programming if multisystem has been selected as NO.

Multisystem account numbers

If MPX was selected as the communication type in section 3.2, a special range of multisystem account numbers must be used. The account number must be five digits in length. The first digit must be the same as the first digit of the control panel account number specified in section 3.5A. The second digit is always zero. The last three digits are limited to a range of 128 to 999. The last three digits cannot be the same as other multisystem account numbers in other multiplex control panels connected to the same multiplex line.

Below illustrates proper assignment of multiplex account numbers to the DMP receiver system.

Receiver Line	Control Accounts	Multisystem Accounts
1	10000 - 10127	10128 - 10999
2	20000 - 20127	20128 - 20999
3	30000 - 30127	30128 - 30999
4	40000 - 40127	40128 - 40999
5	50000 - 50127	50128 - 50999

- 4.4 [DEVICE X :]** DEVICE DEFINITION - Up to 4 addressable devices can be used on the 1512 and 1912 keypad/expander bus. Each can be one of four types:
- [770 772 704 NONE]** 770 - The device is an alpha display keypad, Model 670, 770 or 771.
772 - The device is a non-alpha display keypad, Model 772 or 773.
704 - The device is a loop expander, Model 704, 705, 714, or 715.
NONE - No device is used.
- [774]** 774 - The device is a non-alpha display keypad, Model 774.
- 4.5 [SYSTEM NO: X]** SYSTEM NUMBER - If multisystem was selected as YES in section 4.2 each device must be assigned to one of the four specific systems. This option does not appear for programming if multisystem has been selected as NO.

Control Setup continued

4.6 Multisystem Definitions

When multisystem is selected as YES in section 4.2, various programming and user functions change slightly in their operation. Some are available for each system independently. Some are shared by each system. A definition for each function is given in the following sections 4.6A through 4.6Y.

4.6A Communication

All control panel reports are transmitted using the account number you programmed in communication sections 3.5A and 3.6A. These reports include, AC power, battery, tamper, phone line monitors, automatic recall, and other non-multisystem supervisory reports. All other reports use the system account number you programmed in section 4.3.

4.6B Remote Options

All options are shared by each system.

4.6C Set System Number

This menu option appears only when multisystem is selected as YES. It is used to specify which system is being programmed in sections 7 to 13.

4.6D System Reports

All reports are independent for each system.

4.6E System Options

All options are independent for each system, except AC power fail delay.

4.6F Output Options

All options are independent for each system, except communication fail output. Any overlapping output selections function for both systems with the last off time-out having priority. The fire type bell action has priority over all other loop types. Preceding off time-outs are indicated by a two second off position.

4.6G Menu Display

All menu items are independent for each system.

4.6H Status List

All options are independent for each system.

4.6I Area Information

All areas and options are independent for each system. There are up to four areas available in each 1912 panel. You can distribute the four areas among the programmed systems as needed. Total areas for all systems combined cannot exceed four.

4.6J Loop Information

All loops and loop options are independent for each system. Each loop number is defined by its hardware location on the panel and can only be used within one system. Overlapping relay output actions from different systems are prioritized as follows:

- 1) Off
- 2) Pulse
- 3) Steady/Follow
- 4) Momentary

4.6K Alarm Silence

If alarm silence is accessed from a keypad assigned to the system that activated the alarm, the bell output is cancelled. If a second system has activated the alarm, the first silence command is acknowledged by a two second silence. When both systems have silenced the alarm, the bell output is cancelled.

Control Setup continued

- 4.6L Fire Reset**
When activated, a fire reset is done on all systems.
- 4.6M Door Access**
Independent by system.
- 4.6N Armed Areas**
Independent by system.
- 4.6O Outputs ON/OFF**
Uses same priority as overlapping loop activation of outputs. See Section 4.2J.
- 4.6P Loop Status**
Independent by system.
- 4.6Q Bypass Loops**
Independent by system.
- 4.6R Loop Monitor**
Independent by system.
- 4.6S System Status**
Displays shared control panel monitors.
- 4.6T System Test**
Activates shared control panel test. Sends low battery and system test reports using the control panel's account number.
- 4.6U User Codes**
In multisystem mode the 32 user code numbers are divided into eight per system. Each ranges from user code one to user code eight. User code one in each system is independently selectable as an ambush code.
- 4.6V Schedules**
Permanent and Temporary schedules are independent by area unless Area Schedules has been selected as 1. See section 8.16. The two output schedules are shared by the control panel and can be programmed from any system.
- 4.6W Time**
Shared by each system.
- 4.6X Remote Authorize**
Shared by each system.
- 4.6Y Display Events**
Displays activity associated with a system at assigned system keypads only. Displays control panel activity at all keypads.

5.1 Remote Options

This allows you to enter the information needed for Remote Command/Remote Programming operation. The options you need to specify are:

	Reference
Remote Key	5.2
Manufacturer Authorization	5.3
Armed Number of Rings	5.4
Disarmed Number of Rings	5.5
Alarm Receiver Authorization	5.6
Service Receiver Authorization	5.7
Remote Phone Number	5.8
Remote Disarm	5.9

A description of each Remote Option follows:

5.2 [RMT KEY: ***]** REMOTE KEY - This is an eight digit code used by the control panel to verify communication from the receiver. The remote command/programming receiver must give the correct key to the control panel before any remote functions are allowed. The existing key is never displayed by the programmer. All panels are shipped from the factory with the key preset as eight spaces. DMP Security Information Management System (SIMS) software, version 300 or higher, allows you to keep a file for each key by account number.

5.3 [MFG AUTH NO YES] MANUFACTURER AUTHORIZATION - When YES is selected, DMP service technicians can access the control panel to aid in system service or troubleshooting. This authorization automatically expires within one hour.

DMP remote service is provided on a read only basis: DMP technicians can look at the system programming and make suggestions but alterations can only be accomplished locally by the installing company's service personnel.

5.4 [ARM RINGS:] ARMED RINGS - This is the number of rings the control panel counts before answering the phone line when all areas of the control are armed. Any number from 1 to 15 can be entered. If zero is entered, the panel does not answer the phone when all areas of the system are armed.

5.5 [DISARM RINGS:] DISARMED RINGS - This is the number of rings the control panel counts before answering the phone line while any areas of the control are disarmed. Any number from 1 to 15 can be entered. If zero is entered, the panel does not answer the phone when any area of the system is disarmed.

5.6 [ALR RCVR NO YES] ALARM RECEIVER AUTHORIZATION - YES enables remote commands and programming to be accepted from the main central station receiver. Other authorizations such as end user remote authorization and remote key can also be required.

When NO is selected, remote commands and programming are not accepted from the main central station receiver. This option is factory preset as NO.

When YES is selected the panel requests the receiver key on its next dial attempt to the main central station receiver. The panel retains this **alarm receiver key** in memory and accepts remote commands from the alarm receiver. If an alarm occurs during a remote connect, the alarm report is transmitted to the alarm receiver only.

Remote Options continued

- 5.7 [SVC RCVR NO YES] SERVICE RECEIVER AUTHORIZATION - YES enables remote commands and programming to be accepted from a secondary service receiver other than the main central station receiver. Other authorizations such as end user remote authorization and remote key can also be required.

When NO is selected remote commands and programming are not accepted from a secondary service receiver.

This option is factory preset as YES. When the service receiver first calls the panel, the panel requests the **service receiver key**. The panel retains this **service receiver key** in memory and accepts remote commands from the service receiver.

If an alarm occurs during a remote connect, the panel disconnects from the service receiver and calls the alarm receiver. Alarm reports are only transmitted to the central station alarm receiver. It is important that the **alarm receiver key** and the **service receiver key** programmed at the central station are different so the panel knows which receiver it's transmitting to.

- 5.8 [REMOTE PHONE NO.] REMOTE PHONE NUMBER - This is the phone number the panel dials when remote programming is requested. If a phone number is entered here, the panel allows remote commands and programming only after it has first been called by the authorized receiver, disconnected, and has redialed the remote phone number.

Press COMMAND
[enter phone number]

If no number is entered, the panel allows remote commands and programming without disconnecting and redialing. The phone number can be up to 15 digits in length. Enter a D for dial tone detect and a P for a 3 second pause.

Important: Do not program any letters other than P or D.

- 5.9 [DISARM NO YES] REMOTE DISARM - YES enables the control to be disarmed remotely. Selecting NO disables remote disarming.

6.1 Set System Number

Set system number is only displayed in the programming menu when multisystem has been selected as YES. See section 4.2. Since up to four independent systems can be programmed, it's necessary to select the system to be programmed before proceeding to sections 7 to 13.

A copy command is also available that copies the option programming from system 1 to systems 2 to 4. This greatly reduces programming time when most programming options are the same between systems.

6.2 [SYSTEM NUMBER:] SYSTEM NUMBER - The system number is entered before programming section 7 system reports to section 13 loop information. The system number you select appears to the right of the programming menu. This allows you to verify the correct system is being programmed.

6.3 [COPY? NO YES] COPY OPTIONS - YES copies the system reports, system options,
[SURE? YES NO] output options, menu display, and status list programming to systems 2 to 4. Area information and loop information programming is not copied.

7.1 System Reports

This function allows you to select the reports transmitted to the SCS-1 Security Receiver. Below is a list of reporting options:

	Reference
Opening and Closing Reports	7.2
Abort Reports	7.3
Loop Restoral Reports	7.4
Bypass Reports	7.5
Schedule Change Reports	7.6
Code Change Reports	7.7
Access Keypads	7.8
Ambush	7.9

A description of each report follows:

- 7.2 [OPN / CLOS NO YES]** OPENING AND CLOSING REPORTS - When YES is selected, a report is transmitted to the receiver each time an area is armed or disarmed. The report includes the area number, area name, and the user number of the person operating the system.
- 7.3 [ABORT NO YES]** ABORT REPORT - YES allows the panel to send an alarm abort report any time an alarm has been transmitted and the bell is still sounding. The system must be disarmed and no alarmed loops can still be armed.
- 7.4 [LP RSTRL NO YES]** LOOP RESTORAL REPORT - YES allows the panel to send loop restorals to the receiver. The restoral report includes the loop number, loop name and loop condition.
- 7.5 [BYPASS NO YES]** BYPASS REPORTS - YES allows the panel to send all loop bypasses, resets, and force arms to the receiver. The bypass report includes the loop number, loop name, and the user number of the individual operating the system.
- 7.6 [SCHD CHG NO YES]** SCHEDULE CHANGE REPORTS - YES allows the panel to send all permanent, and temporary schedule changes to the receiver. The report includes the day, opening time, closing time, and the user number making the change.
- 7.7 [CODE CHG NO YES]** CODE CHANGE REPORTS - YES allows the panel to send all code additions and deletions to the receiver. The code change report includes the user number added or deleted and the user number making the change.
- 7.8 [ACS KEY : 1 2 3 4]** ACCESS KEYPADS - This specifies the security command keypad addresses that send door access reports to the receiver. A report is transmitted on each door access made from the selected keypads. Addresses not selected do not send door access reports, The door strike relay functions even if not programmed to report. The report includes the user number and the keypad address that was used.
- 7.9 [AMBUSH NO YES]** AMBUSH - YES allows an ambush report to be sent anytime user code number one is entered at a security command keypad. Selecting NO disables the ambush report and allows user code number one to operate the same as all other codes.

8.1 System Options

This allows you to select system wide parameters used in the operation of the system. The options available are:

	Reference
All/Perimeter	8.2
Armed Display	8.3
Opening Code	8.4
Closing Code	8.5
Closing Wait	8.6
Closing Check	8.7
Any Bypass	8.8
Entry Delay 1	8.9
Entry Delay 2	8.10
Exit Delay	8.11
Loop Retard Delay	8.12
Power Fail Delay	8.13
Swinger Bypass Trips	8.14
Reset Swinger Bypass	8.15
Area Schedules	8.16
Save Monitors	8.17

A description of each System Option follows:

8.2 [ALL/PRM NO YES] ALL/PERIMETER - YES allows the system to operate as an All/Perimeter Arming System. Only two burglary areas are active, Perimeter and Interior. This type of system is referred to as an All/Perimeter System.

NO allows the system to operate as an Area Arming System. Up to four independent burglary areas can be used in an Area System.

Up to four areas available in multisystem: When using multisystem, you can have a maximum of four areas for the entire panel. The four areas can be distributed between the systems as needed. Total areas for all systems combined cannot exceed four.

8.3 [ARM DSPY NO YES] ARMED DISPLAY - YES allows the armed area status to be displayed on all Security Command keypads. Armed area status is displayed as part of the keypad's status list display. See section 11. The keypad stays in the armed display until the user chooses to go to system arming, disarming, or a menu option. If the system is an All/ Perimeter system, the display reads ON when any area is armed. If the system is an Area system, the display shows the number of the areas that are armed. For example, [1 2 3 4] when all four areas are armed. In both systems the display remains blank if all areas are disarmed.

8.4 [OPN CODE NO YES] OPENING CODE - YES requires a user code number for disarming regardless of any temporary or permanent schedule. If NO is selected, a code number is not required for disarming during a scheduled period.

8.5 [CLS CODE NO YES] CLOSING CODE - When YES is selected a code number is required for system arming. If NO is selected a code number is not required for system arming.

8.6 [CLS WAIT NO YES] CLOSING WAIT - When YES is selected the keypad waits for an acknowledgment from the central station receiver before displaying the SYSTEM ON message during arming. Exit delays are extended during this period and the display reads ONE MOMENT....

Opening and Closing Reports must be selected as YES to allow Closing Wait to function. See section 7.2.

System Options continued

- 8.7 [CLS CHK NO YES]** CLOSING CHECK - When YES is selected the panel checks to see that all areas of the system are armed after temporary or permanent schedules have expired. If the Closing Check finds any areas disarmed past the scheduled time the keypad selected to display System Trouble Status emits a steady beep and displays CLOSING TIME!. See section 11.3.
- If multiple area schedules have been selected in section 8.16, the appropriate area name is displayed followed by - LATE. The steady beep is silenced by pressing any top row select key. If the system is not armed or a temporary schedule not extended within ten minutes, a No Closing Report is transmitted to the central station receiver. If the area has been disarmed outside of any permanent or temporary schedule, the closing check sequence occurs one hour after the area was disarmed.
- 8.8 [ANY BYPS NO YES]** ANY BYPASS - When YES is selected loops can be bypassed without a code number during the arming sequence. A code number is always required to use the Bypass Loops option from the menu.
- 8.9 [ENTRY DLY 1 :]** ENTRY DELAY 1 - This is the entry delay for all exit type loops that are programmed to use Entry Delay 1. When an armed exit type loop is opened or shorted, the prewarn tone begins sounding and ENTER CODE:- displays on all keypads programmed to prewarn for that loop.
- The system must be disarmed before the delay expires or an alarm will be transmitted. All loops in that area are delayed along with the exit type loop. The entry delay can be from zero to 250 seconds.
- 8.10 [ENTRY DLY 2 :]** ENTRY DELAY 2 - This is the entry delay for all exit type loops programmed to use Entry Delay 2. When an armed exit type loop is opened or shorted, the prewarn tone begins sounding and ENTER CODE:- displays on all keypads programmed to prewarn for that loop.
- The system must be disarmed before the delay expires or an alarm will be transmitted. All loops in that area are delayed along with the exit type loop. The entry delay can be from zero to 250 seconds.
- 8.11 [EXIT DELAY :]** EXIT DELAY - This is the exit delay time assigned to all exit type loops. When the loop is armed, all activity on that loop and other loop types in the same area are ignored until the exit delay expires. This delay countdown is displayed on the keypad. If an exit type loop is in a bad condition at the end of the exit delay, the entry delay begins immediately.
- If any other loop type is in a bad condition at the end of the exit delay an alarm is indicated. The exit delay can be from zero to 250 seconds.
- 8.12 [RETARD DELAY :]** LOOP RETARD DELAY - This is the retard time assigned to Fire, Supervisory, Auxiliary 1, and Auxiliary 2 type loops. The retard delay only functions when the loop is shorted. The loop must remain shorted for the entire length of the retard delay before being recognized by the panel. The Loop Retard Delay can be from zero to 250 seconds.
- 8.13 [PWR FAIL HRS :]** POWER FAIL DELAY - This option tracks the duration of an AC power failure. When the AC power is off for the entire length of the programmed delay time, an AC power failure report is transmitted to the receiver. The delay time can be from 1 to 9 hours. Programming a zero sends the AC power failure report within 15 seconds. This programming option is shared by all systems when multisystem is used. See section 4.2.

System Options continued

- 8.14 [SWGRBYP TRIPS : ?]** SWINGER BYPASS TRIPS - This is the number of times a loop can go into an alarm or trouble condition in one hour before being automatically bypassed.
- The panel's hour timer starts at 59 minutes past the hour. If the hour timer expires before the trip counter is exceeded, the trip counter returns to zero. If the trip counter is exceeded before the hour expires, the loop is automatically bypassed by the panel. A report of the automatic bypass is transmitted if Bypass Reports has been selected as YES. See section 7.5.
- Bypassed loops are automatically reset when they are disarmed. All 24 hour loops are reset when any area of the system is disarmed. Swinger Bypass Trips can be programmed from one to seven. If zero is entered, Swinger Bypass does NOT function.
- 8.15 [RST SBYP NO YES]** RESET SWINGER BYPASS - When YES is selected, an automatically bypassed loop is reset if it remains in a normal condition for one complete hour after being bypassed. A report of the automatic reset is transmitted if Bypass Reports has been selected as YES. See section 7.5.
- 8.16 [AREA SCHEDULES: ?]** AREA SCHEDULES - This is the number of permanent and temporary area opening/ closing schedules the system uses. The valid selections are 1 and 4 for the 1912 panel and 1 or 2 for the 1512 panel. If 1 is selected, the end user can enter one permanent and temporary schedule for the entire system.
- If 2 or 4 is selected, a separate set of schedules exists for all areas with a maximum of one available for each area.
- 8.17 [SAV MON NO YES]** SAVE MONITORS - When YES is selected, the loop numbers that have been placed into loop monitor are retained in memory when an area is armed. The loop functions as programmed during the armed state but returns to the monitor mode automatically when disarmed.
- If NO is selected, a loop is cleared from monitor mode when its area is armed and must be reentered when the area is disarmed.

9.1 Output Options

This function allows you to program the Bell Output functions and certain Relay Output options. Dry contact relays and voltage outputs are functional on the Model 1912. The specifications to be made are:

	Reference	
Bell Cutoff Time	9.2	
Automatic Bell Test	9.3	
Bell Action for . . .	9.4	
Fire Loops	9.4A	
Burglary Loops	9.4B	
Supervisory Loops	9.4C	
Panic Loops	9.4D	
Emergency Loops	9.4E	
Auxiliary 1 Loops	9.4F	
Auxiliary 2 Loops	9.4G	
Output Action for . . .	9.5	
Cutoff Output	9.5A	
Cutoff Time	9.5A1	(Functional on the Model 1912)
Communication Fail Output	9.5B	
Fire Alarm Output	9.5C	
Fire Trouble Output	9.5D	

A description of each output option follows:

9.2 [BELL CUTOFF :] BELL CUTOFF TIME - This is the maximum time the Bell Output remains on before being automatically silenced. If the Bell Output is manually silenced, the cutoff time is reset. The Bell Cutoff Time can be from one to 99 minutes. If zero is entered, the bell cutoff will not function.

9.3 [BELL TST NO YES] AUTOMATIC BELL TEST - When YES is selected the Bell Output is turned on for two seconds each time a system is completely armed.

9.4 [BELL ACTION] Bell Action defines the type of Bell Output for loop alarms. Trouble conditions do not activate the Bell Output. There are seven loop types you can program individually for Bell Output.

To provide a steady Bell Output, enter S. For a pulsed output, enter P. For no Bell Output, enter N.

Below is a list of the seven loop types:

9.4A [FIRE TYPE : ?] - Defines Bell Action for Fire Type Loops

9.4B [BURGLARY TYPE : ?] - Defines Bell Action for Burglary Type Loops

9.4C [SUPRVSRY TYPE : ?] - Defines Bell Action for Supervisory Type Loops

9.4D [PANIC TYPE : ?] - Defines Bell Action for Panic Type Loops

9.4E [EMERGNCY TYPE : ?] - Defines Bell Action for Emergency Type Loops

9.4F [AUXLRY 1 TYPE : ?] - Defines Bell Action for Auxiliary 1 Type Loops

9.4G [AUXLRY 2 TYPE : ?] - Defines Bell Action for Auxiliary 2 Type Loops

9-OUTPUT OPTIONS

Output Options continued

9.5 [OUTPUT ACTION . .]

Output Action defines options you can assign to the two dry contact Relay Outputs and the four 12 VDC outputs of the Model 1912. The maximum current draw from each output is 50mA.

9.5A [CUTOFF OUTPUT:] CUTOFF OUTPUT - Any one output may be programmed to turn off after a specified delay. Any relay output from 1 to 6 can be used. If this option is not used, enter zero.

9.5A1 [CUTOFF TIME:] CUTOFF TIME - If a cutoff output is assigned above, the cutoff time is requested. This is the maximum time the cutoff output remains on before being automatically turned off by the panel. If the output is manually silenced, the cutoff time is reset. The Cutoff Time can be from 1 to 99 minutes. If zero is entered, the cutoff does NOT function.

9.5B [COMM FAIL OUT:] COMMUNICATION FAILURE OUTPUT - This output is turned on for any of the following reasons:

- a DD system fails to communicate on three successive dial attempts
- a MPX system does not communicate with the receiver for 150 seconds or if the backup communication module has transmitted a report
- a valid device address fails to respond to the control panel. This output is turned off automatically when the system is armed, disarmed, or when fire reset is activated.

If none of these options are used, enter zero.

9.5C [FIRE ALRM OUT :] FIRE ALARM OUTPUT - This output is turned on any time a fire type loop is placed in alarm. The output is turned off when you perform a Fire Reset and no fire type loops are in alarm.

9.5D [FIRE TRBL OUT :] FIRE TROUBLE OUTPUT - This output is turned on any time a fire type loop is placed in trouble or when a supervisory type loop is placed in alarm or trouble. The output is turned off when all fire and supervisory type loops are restored.

10.1 Menu Display

Menu Display allows you to select the Menu options displayed on Security Command keypads. Menu options available are:

	Reference
Arm/Disarm	10.2
Alarm Silence	10.3
Fire Reset	10.4
Door Access	10.5
Armed Areas	10.6
Outputs	10.7 (Functional on the Model 1912)
Loop Status	10.8
Bypass Loops	10.9
Loop Monitor	10.10
System Status	10.11
System Test	10.12
User Codes	10.13
Schedules	10.14
Time	10.15
Remote Authorization	10.16
Display Events	10.17

A description of each menu option follows:

- 10.2 [ARM / DIS NO YES]** ARM/DISARM allows the user to arm and disarm the areas in a burglary system.
- 10.3 [ALM SLNC NO YES]** ALARM SILENCE allows the user to silence the bell output.
- 10.4 [FIRE RST NO YES]** FIRE RESET allows the user to reset smoke detectors. The smoke detector output is turned off for five seconds and then turned back on. This function also clears fire and supervisory type loops from the status list.
- 10.5 [DOOR ACS NO YES]** DOOR ACCESS allows the user to activate the door strike relay on a keypad. The door strike relay turns on for five seconds. Not all Security Command keypads provide a door strike relay.
- The 1912 Command Processor panel has not been investigated as an access control system per UL standard 294 - Access Control System Units.
- 10.6 [ARM AREA NO YES]** ARMED AREAS allows the user to display a list of the armed areas in the system. Each area is displayed with name and number.
- 10.7 [OUTPUTS NO YES]** OUTPUTS allows the user to manually control the dry contact relay outputs 1 and 2, as well as the voltage outputs 3 to 6 on the 1912 panel.
- 10.8 [LP STATS NO YES]** LOOP STATUS allows the user to display a list of armed, bypassed, or alarmed loops; or check the status of an individual loop.
- 10.9 [BYPAS LP NO YES]** BYPASS LOOPS allows the user to bypass individual loops out of the system. It is also used to reset a bypassed loop back into the system. A bypassed loop is automatically reset each time it's disarmed.
- 10.10 [LOOP MON NO YES]** LOOP MONITOR - allows the user to monitor selected disarmed loops and display their name when faulted.
- 10.11 [SYS STATS NO YES]** SYSTEM STATUS allows the user to display the status of the internal system monitors. The monitors are AC power, battery power, panel tamper, and phone line.

Menu Display continued

- 10.12 [SYS TEST NO YES]** SYSTEM TEST allows the user to test the bell circuit, battery, and communication to the SCS-1 receiver. The test results are displayed at the keypad after each test.
- 10.13 [USR CODE NO YES]** USER CODES allows the user to add and delete user codes held in the system memory.
- 10.14 [SCHEDULS NO YES]** SCHEDULES allows the user to enter daily on and off times for the dry contact relay outputs 1 and 2, plus temporary and permanent opening and closing schedules.
- Program as YES to enable the keypad time display. The current time does not display at the keypads unless this program option is YES.
- 10.15 [TIME NO YES]** TIME allows the user to change the current day of the week, time of day and date of year from the keypad. SCHEDULES must be set to YES.
- 10.16 [RMT AUTH NO YES]** REMOTE AUTHORIZATION - YES requires the user to enter a level 8 code from the Remote Authorization menu option before any remote commands or programming can be done. Each end user authorization expires within one hour.
- If NO is selected, Remote Authorization is not displayed in the end user menu and is not required before performing remote commands or programming.
- 10.17 [DIS EVNT NO YES]** DISPLAY EVENTS allows the user to display past loop activity, area arming and disarming, and internal system status.

11.1 Status List

This function allows you to select the loop alarms and troubles, and system monitor troubles displayed at the keypads. The Status List function operates automatically when the keypad is not performing any other function.

The keypad stays in the Status List until the user chooses to go to system arming/disarming or a menu option. Status List alternates with the armed display, if that was selected in section 8.3. You can choose to have System Monitor troubles placed in the list, the different loop types placed in the list, and at which keypad addresses they'll be displayed. The selections to make while programming are:

	Reference
System Monitor Troubles	11.3
Fire Loops	11.4
Burglary Loops	11.5
Supervisory Loops	11.6
Panic Loops	11.7
Emergency Loops	11.8
Auxiliary 1 Loops	11.9
Auxiliary 2 Loops	11.10

A description of how each will be displayed in the Status List follows:

11.2 [DISPLAY KEYPADS:]

The Display Keypads section defines which keypad addresses display the various status information. Any combination of addresses can be entered to display the status items that follow. If you don't want a particular status item to display, do not enter any addresses.

11.3 [SYS TRB 1234] SYSTEM MONITOR TROUBLES - Specifies the addresses where any trouble on a System Monitor is displayed. The System Monitors are:

A.C. Power
 Battery Power
 Panel Box Tamper (Functional on the Model 1912)
 Phone Line 1 (Functional on the Model 1912)
 Phone Line 2 (Functional on the Model 1912, requires Model 893)

The name of the System Monitor is placed in the Status List and the keypad steady trouble buzzer sounds. The buzzer remains on until the monitor restores or any top row select key is pressed on the keypad. The name remains in the list until the condition is restored.

11.4 [FIRE 1234] FIRE LOOPS - Specifies the addresses where all fire loop alarms and troubles are placed in the Status List. The loop name is displayed and, if it's a trouble condition, the keypad steady trouble buzzer sounds. The buzzer remains on until any top row select key is pressed on the keypad. The name remains in the list until it is cleared by the Fire Reset menu option.

Status List continued

- 11.5 [BURGLRY] 1234]** BURGLARY LOOPS - Specifies the addresses where all burglary loop alarms and troubles are placed in the status list. Burglary loops include Night, Day, and Exit type loops. Burglary loop troubles remain in the list until the loop is restored.
- If it's an alarm, only the last burglary loop tripped remains in the list, and the alarm remains in the list until another burglary loop goes into alarm or any area of the system is disarmed. This is to ensure that if a burglary is in progress the last loop tripped remains in the list even if the loop has been restored.
- The keypad buzzer sounds for one second on burglary alarms.
- 11.6 [SPRVSRY] 1234]** SUPERVISORY LOOPS - Specifies the addresses where all supervisory loop alarms and troubles are placed in the status list. The function of supervisory loops in the status list is the same as fire type loops.
- 11.7 [PANIC] 1234]** PANIC LOOPS - Specifies the addresses where all panic loop alarms and troubles are placed in the status list. The name of the loop remains in the list until the loop restores. The keypad buzzer does not sound for panic alarms or troubles.
- 11.8 [EMERGCY] 1234]** EMERGENCY LOOPS - Specifies the addresses where all emergency loop alarms and troubles are placed in the status list. The name of the loop remains in the list until the loop restores. The keypad buzzer does not sound for emergency alarms or troubles.
- 11.9 [AUX 1] 1234]** AUXILIARY 1 LOOPS - Specifies the addresses where all auxiliary 1 loop alarms and troubles are placed in the status list. The name of the loop remains in the list until the loop restores. The keypad buzzer does not sound for auxiliary 1 alarms or troubles.
- 11.10 [AUX 2] 1234]** AUXILIARY 2 LOOPS - Specifies the addresses where all auxiliary 2 loop alarms and troubles are placed in the status list. The name of the loop remains in the list until the loop restores. The keypad buzzer does not sound for auxiliary 2 alarms or troubles.

12.1 Area Information

Area Information allows you to assign functions to the different areas that can arm and disarm non-24 hour type loops. The non-24 hour loops, programmed in section 13, must be assigned to an active area. An area is activated when it is given a name. An Area Arming System can have up to four independent areas on the Model 1912 and up to two on the Model 1512. If multisystem has been selected as YES on the Model 1912, the maximum control panel capacity of four areas can be spread over the four systems in any combination. See section 4.6I.

A name is given to each active area to be displayed to the user in the various arming and disarming procedures so that the user is not required to memorize area numbers. The user can instead associate a name with a particular area of the system.

The various area functions that can be selected are:

	Reference
Area Number	12.2
Area Name	12.3
Automatic Arming	12.4
Automatic Disarming	12.5
Armed Output Number	12.6

12.2 [AREA NO :-] AREA NUMBER - Enter the area number you wish to program. An area arming system can have up to four independent areas on the 1912 panel and up to two on the 1512 panel.

12.3 [NAME:] AREA NAME - The Area Name can be up to 10 alphanumeric characters. It is important to note that only areas having loops assigned to them are given names. All others are marked unused.

To mark an area unused, delete the old name by pressing a top row select key, then press the COMMAND key. The programmer automatically programs the name as *UNUSED*. If you have already cleared Area Information during Initialization, the areas will already be marked *UNUSED*. See section 2.6.

12.4 [AUTO ARM NO YES] AUTOMATIC ARMING - When YES is selected, the area automatically arms according to permanent, temporary, or extended schedules. If closing check, section 8.7, is selected as YES the automatic arming function does not take place until the expiration of the ten minute closing check delay.

Bad loops are handled according to the option selected in section 12.4A. If a closing report is transmitted the user number is indicated as SCH on the SCS-1 receiver.

If the area has been disarmed outside of any permanent or temporary schedule, the closing check sequence occurs one hour after the area was disarmed.

12-AREA INFORMATION

Area Information continued

- 12.4A [BAD LOOPS: XXXX]** BAD LOOPS - At the time of automatic arming some loops in the area may not be in a normal condition. You must program how the panel is to respond to bad loops.
- [BYP FORC REF]** BYP - All bad loops are bypassed. A report of the bypass is transmitted if bypass reports has been selected as YES. See section 7.6. The report indicates SCH as the user number.
- FORC - All bad loops are force armed. Loops armed in a bad condition are capable of restoring and transmitting an alarm if tripped. A report of the forced loop is transmitted if Bypass Reports has been selected as YES. See section 7.6. The report indicates SCH as the user number.
- REF - The automatic arming is refused and no arming takes place. A no closing report is transmitted regardless of the Closing Check selection. See section 8.7.
- 12.5 [AUTO DIS NO YES]** AUTOMATIC DISARMING - When YES is selected, the area automatically disarms according to permanent or temporary schedules. If an opening report is transmitted the user number is indicated as SCH.
- 12.6 [OUTPUT NO: -]** ARMED OUTPUT NUMBER - When the area is armed the assigned output is turned on. The output is turned off when the area is disarmed. This is functional on the 1912 panel.

13.1 Loop Information

Loop Information allows you to define the operation of each protection loop used in the system. All protection loops, whether located on a command processor panel, Security Command keypad, or loop expander are programmed the same way.

The specifications for each loop are:

	Reference	Loop Number	Assignments
Loop Number	13.2	Control Panel	Loop 1-5
Loop Name	13.3	Address 1	Loop 11-14
Loop Type	13.4	Address 2	Loop 21-24
Area Assignment	13.5	Address 3	Loop 31-34 (1912 only)
Alarm Action	13.7	Address 4	Loop 41-44 (1912 only)

A description of each specification follows:

13.2 [LOOP NO : -] LOOP NUMBER - Enter the loop number you want to define.

13.3 [NAME :] LOOP NAME - Loop names can have up to 10 alphanumeric characters. A name is given to each loop in the system. The name can display at the keypads during arming and disarming so the user does not have to memorize loop numbers. Users can associate a loop name with a particular protection point. A loop that is not part of the system must be marked unused.

To mark a loop unused, delete the old name by pressing a top row select key, then press the COMMAND key. The programmer automatically programs the name as * UNUSED *. If you have already cleared Loop Information during Initialization, the loops will be marked * UNUSED *. See section 2.5.

13.4 [LOOP TYPE :] LOOP TYPE - The Loop Type defines the panel's response to the loop being faulted. This is called the Alarm Action. There are 10 different responses the Alarm Action can initiate:

	Reference
Disarmed Open	13.8
Disarmed Short	13.9
Armed Open	13.9
Armed Short	13.9
Swinger Bypass	13.10
Prewarn Address	13.11
Entry Delay	13.12
Retard	13.13
Presignal Address	13.14
Fast Response	13.15

When you assign a Loop Type to a loop, all responses are made automatically for the loop. There are 12 Loop Types to choose from. The functional details of each response are described in sections 13.7A to 13.15.

To enter a new Loop Type, press a top row select key. The display lists four Loop Types at a time.

- [— NT DY EX] Blank, Night, Day, Exit
- [FI PN EM SV] Fire, Panic, Emergency, Supervisory
- [A1 A2 FV AR] Auxiliary 1, Auxiliary 2, Fire Verify, Arming (keyswitch)

When the correct Loop Type is displayed, press the select key beneath it. The chart on the next page gives a detailed outline of the Alarm Action for each Loop Type.

13-LOOP INFORMATION

13.4A LOOP TYPE SPECIFICATIONS

BLANK

Specifying a loop type as BLANK leaves the current Alarm Action programming the same, but no Loop Type report is communicated. Output programming is functional on the 1912 panel only.

		NIGHT			
Alarm Action:	Disarmed Open:	A T	⊖	Output 0	Steady Pulse Momentary Follow
	Disarmed Short:	A T	⊖	Output 0	Steady Pulse Momentary Follow
	Armed Open:	(A) T	-	Output 0	Steady Pulse Momentary Follow
	Armed Short:	(A) T	-	Output 0	Steady Pulse Momentary Follow
	Swinger Bypass:	NO	(YES)		

		DAY				
Alarm Action:	Disarmed Open:	A	(T)	-	Output 0	Steady Pulse Momentary Follow
	Disarmed Short:	A	(T)	-	Output 0	Steady Pulse Momentary Follow
	Armed Open:	(A)	T	-	Output 0	Steady Pulse Momentary Follow
	Armed Short:	(A)	T	-	Output 0	Steady Pulse Momentary Follow
	Swinger Bypass:	NO	(YES)			

		EXIT			
Alarm Action:	Disarmed Open:	A T	⊖	Output 0	Steady Pulse Momentary Follow
	Disarmed Short:	A T	⊖	Output 0	Steady Pulse Momentary Follow
	Armed Open:	(A) T	-	Output 0	Steady Pulse Momentary Follow
	Armed Short:	(A) T	-	Output 0	Steady Pulse Momentary Follow
	Swinger Bypass:	NO	(YES)		
	Prewarn Address:	(1 2 3 4)			
	Entry Delay:	(1 2)			

		FIRE OR FIRE VERIFY				
Alarm Action:	Armed Open:	A	(T)	-	Output 0	Steady Pulse Momentary Follow
	Armed Short:	(A)	T	-	Output 0	Steady Pulse Momentary Follow
	Swinger Bypass:	(NO)	YES			
	Retard:	(NO)	YES			
	Presignal Address:	1 2 3 4				

		PANIC				
Alarm Action:	Armed Open:	A	(T)	-	Output 0	Steady Pulse Momentary Follow
	Armed Short:	(A)	T	-	Output 0	Steady Pulse Momentary Follow
	Swinger Bypass:	NO	(YES)			

		EMERGENCY				
Alarm Action:	Armed Open:	A	(T)	-	Output 0	Steady Pulse Momentary Follow
	Armed Short:	(A)	T	-	Output 0	Steady Pulse Momentary Follow
	Swinger Bypass:	NO	(YES)			

		SUPERVISORY				
Alarm Action:	Armed Open:	A	(T)	-	Output 0	Steady Pulse Momentary Follow
	Armed Short:	(A)	T	-	Output 0	Steady Pulse Momentary Follow
	Swinger Bypass:	(NO)	YES			
	Retard:	(NO)	YES			
	Presignal Address:	1 2 3 4				

		AUXILIARY 1				
Alarm Action:	Disarmed Open:	A	(T)	-	Output 0	Steady Pulse Momentary Follow
	Disarmed Short:	(A)	T	-	Output 0	Steady Pulse Momentary Follow
	Armed Open:	A	(T)	-	Output 0	Steady Pulse Momentary Follow
	Armed Short:	(A)	T	-	Output 0	Steady Pulse Momentary Follow
	Swinger Bypass:	NO	(YES)			
	Retard:	(NO)	YES			
	Presignal Address:	1 2 3 4				

		AUXILIARY 2				
Alarm Action:	Disarmed Open:	A	(T)	-	Output 0	Steady Pulse Momentary Follow
	Disarmed Short:	(A)	T	-	Output 0	Steady Pulse Momentary Follow
	Armed Open:	A	(T)	-	Output 0	Steady Pulse Momentary Follow
	Armed Short:	(A)	T	-	Output 0	Steady Pulse Momentary Follow
	Swinger Bypass:	NO	(YES)			
	Retard:	(NO)	YES			
	Presignal Address:	1 2 3 4				

Loop Information continued

If the Loop Type selected is Blank, Night, Day, Exit, Auxiliary 1, Auxiliary 2, or Arming, the loop must be assigned to an area for arming and disarming. If the Loop Type selected is Fire, Panic, Emergency, or Supervisory, it is a 24 hour loop that is always armed and no area assignment is needed. Go ahead to section 13.6

13.5 Area Assignment

If the system is an All/Perimeter system, the area assignment is made as described in section 13.5A.

If the system is an Area system, the area assignment is made as described in section 13.5B.

13.5A [AREA :] ALL/PERIMETER - In an All/Perimeter system, a non-24 hour loop must be assigned to the Interior area or the Perimeter area for arming and disarming. To change an area assignment, press a top row select key.

[INT. PERIM] The display lists the two areas for you to choose from.

13.5B [AREA NO :] AREA NUMBER - In an Area system, a non-24 hour loop must be assigned to one of up to four areas. This is the area the loop is armed and disarmed by.

13.5C [AREAS: 1 2 3 4] ARMING LOOP AREA ASSIGNMENT - If the loop has been programmed as Arming Type (AR), the only programming information to enter after the type selection are the areas it controls. Areas 1 to 4 can be selected on the 1912 panel and 1 or 2 on the 1512 panel. If the All/Perimeter system is being used, Area 1 = Perimeter and Area 2 = Interior.

When the loop is shorted, the selected areas are armed. When restored to normal, the selected areas are disarmed. If the loop is opened from a normal (disarmed) state, a trouble is reported. If opened from a shorted (armed) state, an alarm is reported and the loop is disabled until another disarming occurs within the system.

To visually indicate the armed or disarmed condition, an Armed Output Number, section 12.6, should be assigned and an LED for each area placed at the keyswitch. The LED turns on and off to visually indicate to the user the area(s) armed or disarmed. If any bad loops are present when the keyswitch is armed, the LED delays lighting for five seconds. If during the five second delay the keyswitch is turned to the disarm position, no arming takes place. If the keyswitch stays in the armed position for the entire five seconds, the bad loops are force armed and the LED turns on.

13.6 [NEXT LP? NO YES] NEXT LOOP - When YES is selected, the programming for the loop terminates and the display returns to section 13.2 for you to enter a new loop number. To make any alterations to the Alarm Action for a loop, answer the Next Loop selection with NO. The Alarm Action is then defined in sections 13.7 through 13.15.

13.7 [ALARM ACTION] ALARM ACTION - The Alarm Action section allows you to alter the standard definitions of any Loop Type. The Alarm Action for a loop is stored in memory when the Loop Type is specified in section 13.4. If the Loop Type is Blank, Night, Day Exit, Auxiliary 1, or Auxiliary 2 it's a non-24 hour loop and the Alarm Action programming begins with Disarmed Open.

If the Loop Type is Fire, Panic, Emergency, or Supervisory it's a 24 hour loop that is always armed and the Alarm Action programming begins with Armed Open.

Loop Information continued

13.7A Fire Verify Loop Type

The Fire Verify Loop Type functions the same as Fire Type, with the following exceptions: When a Fire Verify loop initiates an alarm, the panel performs a Fire Reset. If any Fire Verify loop initiates an alarm within 120 seconds after the reset, an alarm is indicated. If an alarm is initiated after 120 seconds, the cycle is repeated.

Fire Verify Loop Types cannot be programmed for RETARD.

13.8 [DISARMED OPEN] DISARMED OPEN - Defines the action taken by the panel when the loop is opened while the area is disarmed. There are three actions to define:

Report to transmit

Relay Output to activate (Functional on Model 1912)

Relay Output action (Functional on Model 1912)

These selections are also made for the Disarmed Short, Armed Open, and Armed Short conditions. A description of each selection follows:

13.8A [MSG : ?] MESSAGE (report) TO TRANSMIT - You can send two report types to the central station receiver: Alarm and Trouble. These are programmed by the characters A and T.

[A T L -] **A** - When you select A, an alarm report is transmitted to the receiver and the bell output activates according to loop type. See section 9.4, Bell Action. The loop name appears in the panel's alarmed loops and status lists.

T - When you select T, a trouble report is transmitted to the receiver and the loop name appears in the panel's alarmed loops and status lists.

L - When you select L, an alarm report is NOT transmitted to the receiver. The bell output activates according to loop type and the loop name appears in the panel's alarmed loops and status lists.

- - When you select a - (dash), reports are NOT transmitted. The bell output does not activate and there is no display in the panel's alarmed loops or status list. Only the relay output selected in section 13.8B operates.

13.8B [OUTPUT NO :] OUTPUT NUMBER - You can specify any of the Relay Outputs on the 1912 to be activated by a loop condition. The output can be activated regardless of the report to transmit. If you do not want an output, press a top row select key and then press COMMAND. An output activated by an armed loop is turned off when the loop's area is disarmed by the user.

13.8C [OUTPUT:] OUTPUT ACTION - When programming an output number for activation, there are four conditions in which that output can be placed. If you did not select an Output Number in 13.8B, this step is skipped.

[SDY PLS MOM FOLW] **STEADY** - The output is turned on and remains on until the area is disarmed, an output cutoff time expires, or the output is reset from the menu.

PULSE - The output alternates on and off.

MOMENTARY - The output is turned on only once for one second.

FOLLOW - The output is turned on and remains on while the loop is in the non-normal condition. When the loop restores, the output is turned off.

Loop Information continued

After you've made the three selections in sections 13.8A through 13.8C, the display prompts you for the same three selections for Disarmed Short, Armed Open, and Armed Short conditions. If the loop is a 24 hour type, only the Armed Open and Armed Short conditions are displayed. When you've programmed all of the loop conditions the Swinger Bypass selection is displayed.

13.10 [SWGR BYP NO YES] SWINGER BYPASS - When you select YES, the loop is bypassed according to the specifications programmed in sections 8.14 and 8.15. If you select NO, the loop is not bypassed.

The remaining Loop Information you need to specify varies with the different Loop Types. Below is a list of the remaining information needed and the appropriate section numbers that define each step:

Loop Type	Remaining Information	Section Numbers
Night, Day Panic, Emergency	None, programming complete	Section 13.15
Exit	Prewarn addresses	Section 13.11
Fire, Supervisory Auxiliary 1 and 2	Retard and Presignal addresses	Sections 13.12 to 13.13

13.11 [PREWARN : 1234] PREWARN ADDRESSES - When the entry delay starts, displays at all prewarn keypads immediately display ENTER CODE:-. You can have the entry delay prewarn buzzer enabled at any combination of the four device addresses. If you want the prewarn to sound at all four addresses, enter each number; even if some of the addresses are loop expanders or keypads in one of the other multisystems. No changes to the Loop Information are necessary if the specific addresses are changed in the future.

To enable a prewarn address, press the matching number key. To delete an address, press the matching number key again. To disable all, press any top row key. Press the COMMAND key when the address selection is complete.

13.12 [ENTRY DELAY: #] ENTRY DELAY - You can program an exit type loop to use Exit Delay 1 or 2. The specific delay times are specified in sections 8.9 and 8.10.

13.13 [RETARD NO YES] RETARD - When you select YES, the loop operates with the retard delay specified in section 8.12. The retard functions only in loop short conditions.

The loop must remain shorted for the full length of the retard delay before the panel recognizes its condition. If you select NO, the loop operates without a retard delay.

13.14 [PRESGNL : 1234] PRESIGNAL ADDRESSES - You can enable any combination of device addresses to sound a presignal tone during the time a loop is in retard delay. The presignal tone silences when the loop restores or the retard delay expires.

To enable a presignal address, press the matching number digit. To disable a presignal address press the matching number digit again. Press the COMMAND key when the address selection is complete.

13.15 [FAST RSP NO YES] FAST LOOP RESPONSE - When you select YES, the normal 300 millisecond loop response delay is reduced to 100 milliseconds.

14.1 Stop

Stop allows you to remove the programmer once programming is complete. When selected, the display reads 891 STOPPED. Place the J16 reset jumper over the reset pins and remove the programmer. Once the programmer is off, remove the reset jumper from J16 to start the system operating.

Always set the panel clock after programming.

15.1 Save Into 891A

This allows you to save the memory of a command processor into the 891/891A programmer. The memory saved includes all the 891/891A programming options and the user programmable information (schedules and codes).

The 891/891A programmer is able to store the memory from two panels. The memory slots in the programmer are referred to as memory A and memory B.

After selecting the Save Into 891A option, you'll be prompted to save the panel's memory into memory A or memory B of the 891A. After the memory is saved, the 891A displays the checksum of the memory saved to confirm it properly saved.

A description of each Save selection follows:

15.2 Save

[**A B STOP**] SAVE A, B, OR STOP - When A or B is selected, the memory of the panel is saved into that portion of the 891A. Saving the memory takes approximately 20 seconds. After saving, the checksum of the 891A is displayed.

When STOP is selected, the load option terminates and the memory of the panel is not saved.

[**ONE MOMENT**] ONE MOMENT - This message is displayed while the memory is being saved into the 891A.

15.3 Checksum

[**CHECKSUM: XXXX**] MEMORY CHECKSUM - The checksum displayed is a calculation of all the data in the 891A memory location. If any part of the memory changes, this checksum changes.

You can compare the 4-digit checksum to the checksum of the panel to make sure the memory was saved properly. When the checksum is displayed, press the COMMAND key to exit the Save Into 891A option.

16.1 Load into Panel

This allows you to load a set of programmed options from the 891A programmer into a panel's memory. The programmed options loaded include the 891A programming options, the user programmable information (schedules and codes).

The 891/891A programmer is able to store the memory from two panels. The memory slots in the programmer are referred to as memory A and memory B.

After selecting the Load Into Panel option, you'll be prompted to load the options stored in memory A or memory B of the 891A. After the memory is loaded, the 891A displays the checksum of the memory saved to confirm it loaded properly.

A description of each selection follows:

16.2 Load

[A B STOP] LOAD A, B, OR STOP - When A or B is selected, the memory in that portion of the 891A is loaded into the command processor panel. The loading time takes approximately .5 seconds. After loading, the checksum of the panel's memory is displayed.

When STOP is selected, the load option terminates and the memory of the 891A is not loaded into the panel.

16.3 Checksum

[CHECKSUM: XXXX] MEMORY CHECKSUM - The checksum displayed is a calculation of all the data in the 891A memory location. If any part of the memory changes, this checksum changes.

You can compare the 4-digit checksum to the checksum of the panel to make sure the memory loaded properly. When the checksum is displayed, press the COMMAND key to exit the Load Into Panel option.

17.1 Compute Checksum

This allows you to see the checksum of the memory A or B locations of the 891A or the memory of the panel. The memory calculated includes the 891A programming options, the user programmable information (schedules and codes), and the status of each loop.

After you select the Compute Checksum option, you'll be prompted to compute the checksum for the A or B memory locations in the 891A or the memory in the panel.

A description of each selection follows:

17.2 Checksum

[A B PNL STOP] CHECKSUM FOR A, B, PANEL OR STOP - When A or B is selected, the checksum for the A or B memory location in the 891A is computed.

When PNL is selected, the checksum for the panel is computed.

When STOP is selected the compute checksum option terminates.

17.3 [CHECKSUM: XXXX] MEMORY CHECKSUM - The checksum displayed is a calculation of all data in the selected memory location. If any part of the memory changes, this checksum changes also. When the checksum is displayed, press the COMMAND key to exit the Compute Checksum option.

B.1 BACKUP WHEN MAIN COMMUNICATION IS DD

As indicated in section 3.3, a backup phone line can be used when the communication type is programmed as DD and the Model 893 Dual Phone Line Module is used on the 1912 Command Processor panel. When the panel has a report to communicate, it begins sending over the main phone line using the first phone number. The panel continues to dial according to the table below until the receiver acknowledges the report.

Dial Attempt	Phone Line	Phone Number
1	Main	First
2	Main	First
3	Backup	First
4	Backup	First
5	Main	Second
6	Main	Second
7	Backup	Second
8	Backup	Second
9	Main	First
10	Main	First

The panel tries a total of 10 times to communicate the report. After the tenth failure to communicate, either dialing stops or the second receiver, if programmed in section 3.7, is attempted. If another event occurs that requires a report to be transmitted, the dialing process is repeated.

B.2 BACKUP WHEN MAIN COMMUNICATION IS MPX

As indicated by section 3.3, a backup dialer phone line can be used when the communication type is programmed as multiplex (MPX) and the 893 Dual Phone Line Module is used on the Model 1912 Command Processor panel. When the panel has a message to report it waits to be polled by the receiver on the MPX communication system. If after 150 seconds a poll has not been received, the panel begins using the backup dialer phone line. If the report is a fire type, this delay is shortened to 75 seconds.

If the panel fails to sense any receiver polling, the time out shortens to 15 seconds. The panel makes ten full dialing attempts according to the chart in section B.1 alternating between phone numbers but only using the backup line. After dialing is complete, commun