

PROGRAMMING GUIDE

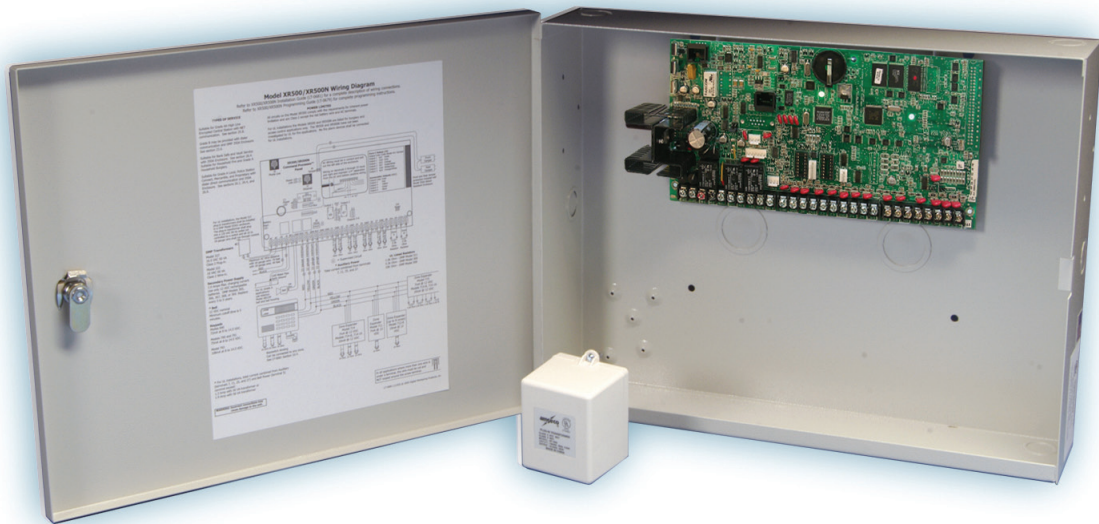

XR100 SERIES CANADIAN COMMAND PROCESSOR™ PANEL



MODEL XR100 SERIES ACCESS CONTROL COMMAND PROCESSOR™ PANEL PROGRAMMING GUIDE

Contains programming instructions for use with the Model XR100 and XR100N Access Control Command Processor™ Panel.

When using the XR100 Series Canadian panel for any ULC or other listing organization's approved methods, refer to this manual and the XR100 Series Canadian Installation Guide (LT-0899CAN). These documents outline the installation and programming requirements of all applications for which the XR100 Series is approved.

INDUSTRY CANADA NOTICE

This Class A digital apparatus complies with Canadian ICES-003.

© 2012 Digital Monitoring Products, Inc.

Information furnished by DMP is believed to be accurate and reliable.
This information is subject to change without notice.

TABLE OF CONTENTS

1.1	Before you Begin	1
	Programming Information Sheet	1
1.2	Getting Started	1
	Accessing the Programmer	1
1.3	Programmer Operation	2
1.4	Programmer Lockout Codes	2
1.5	Reset Timeout	2
1.6	Power Up	2
1.7	Keypads	3
1.8	Special Keys	3
1.9	Entering Alpha Characters	4
1.10	Entering Non-Alpha Characters	4
1.11	Keypad Displays Current Programming	5
1.12	Asterisks in Programming	5
Initialization.....		6
2.1	Initialization	6
2.2	Clear All Memory	6
2.3	Clear All Codes	6
2.4	Clear All Schedules	6
2.5	Clear Display Events Memory	6
2.6	Clear Zone Information	6
2.7	Clear Area Information	6
2.8	Clear Output Information	6
2.9	Clear Communication and Remote Options	7
2.10	Set to Factory Defaults	7
Communication.....		8
3.1	Communication	8
3.2	Account Number	8
3.3	Transmit Delay	8
3.4	Communication Path	8
3.5	Communication Type.....	8
3.6	Path Type.....	9
3.7	Test Report	9
3.8	Test Frequency	9
3.9	Test Day	9
3.10	Test Time	9
3.11	Check In	9
3.12	Fail Time	9
3.13	Receiver IP.....	9
3.14	Receiver Port.....	10
3.15	First Telephone Number	10
3.16	Second Telephone Number	10
3.17	Advanced Programming	10
3.18	First GPRS APN.....	10
3.19	Fail Test Hours.....	10
3.20	Protocol	11
3.21	Retry Seconds	11
3.22	Substitution Code	11
3.23	893A.....	11
3.24	Alarm Switch	11
3.25	Duplicate Alarms.....	11
3.26	Alarm Reports	11
3.27	Supervisory/Trouble Reports.....	12
3.28	Opening/Closing and User Reports.....	12
3.29	Door Access Report.....	12
3.30	Send Communication Trouble	12
3.31	Send Path Information	12

TABLE OF CONTENTS

Network Options (XR100N only)	13
4.1	DHCP Mode Enabled13
4.2	Local IP Address13
4.3	Gateway Address13
4.4	Subnet Mask13
4.5	DNS Server13
4.6	Programming Port.....13
4.7	734N Listen Port.....13
4.8	734N Passphrase13
Messaging Setup	14
5.1	Messaging Setup14
5.2	Enable Messaging14
5.3	System Name14
5.4	Destination 114
5.5	Destination 1 User Number14
5.6	Destination 214
5.7	Destination 2 User Number14
5.8	Destination 314
5.9	Destination 3 User Number.....15
5.10	Email Communication Type.....15
5.11	O/C Email15
5.12	O/C SMS15
5.13	Daily Limit.....15
5.10	SMTP Server15
5.11	SMTP Server Port.....15
5.12	SMTP Username15
5.13	SMTP Password15
Device Setup	16
6.1	Device Setup16
6.2	Device Number.....16
6.3	Device Name16
6.4	Device Type16
6.5	Device Communication Type.....16
6.6	Wireless16
6.6.1	Serial Number16
6.6.2	Supervision Time16
6.7	Access Areas16
6.8	Egress Areas17
6.9	Display Areas17
6.10	Strike Time.....18
6.11	Strike Delay.....18
6.12	Fire Exit Release18
6.13	Output Group18
6.14	Schedule Override18
6.15	Auto Force Arm Device?19
6.16	Door Real-Time Status?19
6.17	Send Door Forced Message?19
6.18	Program 734/734N Options19
6.18.1	Activate Zone 2 Bypass19
6.18.2	Zone 2 Bypass Time.....19
6.18.3	Relock on Zone 2 Change?19
6.18.4	Activate Zone 3 Request to Exit19
6.18.5	Zone 3 REX Strike Time.....20
6.18.6	Activate Onboard Speaker20
6.18.7	Card Options20
6.18.8	Custom Card Definitions20
6.18.9	Site Code Position20
6.18.10	Site Code Length20
6.18.11	User Code Position.....21
6.18.12	User Code Length21
6.18.13	Require Site Code21

TABLE OF CONTENTS

6.18.13.1	Site Code Display	21
6.18.14	Number of User Code Digits	21
6.18.15	No Communication with Panel	21
Remote Options		22
7.1	Remote Options.....	22
7.2	Remote Key	22
7.3	Remote Disarm	22
7.4	Armed Answer Rings.....	22
7.5	Disarmed Answer Rings.....	22
7.6	PC Modem	22
7.7	Alarm Receiver Authorization	22
7.8	Service Receiver Authorization	22
7.9	Manufacturer Authorization	23
7.10	Allow Network Remote	23
7.10.1	Network Programming Port.....	23
7.10.2	Encrypt Network Remote.....	23
7.11	Allow Cellular Remote	23
7.11.1	First GPRS APN.....	23
7.11.2	Encrypt Cellular Remote	23
7.12	Entré Connection	23
7.12.1	Entré Incoming TCP Port	23
7.12.2	Entré IP Address.....	23
7.12.3	Entré Outbound TCP Port	24
7.12.4	Entré Backup IP Address	24
7.12.5	Entré Backup TCP Port	24
7.12.6	Entré Checkin	24
7.12.7	Entré Passphrase	24
7.13	Send Local Changes.....	24
7.13.1	Remote Change IP.....	24
7.13.2	Remote Change Port	24
7.13.3	Remote Telephone Number	24
System Reports.....		25
8.1	System Reports	25
8.2	Abort Report	25
8.3	Restoral Reports	25
8.5	Schedule Change Reports.....	25
8.6	Code Change Reports	25
8.7	Access Keypads	25
8.8	Ambush	25
System Options.....		26
9.1	System Options	26
9.2	System	26
9.3	Instant Arming	26
9.4	Closing Wait	26
9.5	Entry Delay 1	26
9.6	Cross Zone Time.....	27
9.7	Zone Retard Delay	27
9.8	Power Fail Delay	27
9.9	Swinger Bypass Trips	27
9.10	Reset Swinger Bypass	27
9.11	Time Zone Changes	27
9.12	Latch Supervisory Zones.....	28
9.13	Programming Menu Language	28
9.14	User Menu and Status List Language	29
9.15	Bypass Limit.....	29
9.16	House Code.....	29
9.17	Detect Wireless Jamming	29
9.18	Wireless Audible Annunciation	30
9.19	Enable Keypad Panic Keys	30
9.20	Occupied Premise	30
9.21	Enhanced Zone Test.....	30

TABLE OF CONTENTS

9.22	Dual EOL.....	30
9.23	Send 16 Character Names	30
9.24	Keypad Armed LED	30
9.25	Use False Alarm Question	30
Bell Options.....		31
10.1	Bell Options.....	31
10.2	Bell Cutoff Time.....	31
10.3	Automatic Bell Test	31
10.4	Bell Output.....	31
10.5	Bell Action.....	31
10.5.1	Fire Bell Action	31
10.5.2	Burglary Bell Action.....	31
10.5.3	Supervisory Bell Action.....	31
10.5.4	Panic Bell Action	31
10.5.5	Emergency Bell Action.....	31
10.5.6	Auxiliary 1 Bell Action.....	31
10.5.7	Auxiliary 2 Bell Action.....	31
Output Options.....		32
11.1	Output Options.....	32
11.2.1	Cutoff Output	32
11.2.2	Output Cutoff Time.....	32
11.3	Communication Trouble Output.....	32
11.4	Fire Alarm Output	32
11.5	Fire Trouble Output.....	32
11.6	Panic Alarm Output.....	33
11.7	Ambush Output	33
11.8	Entry Output	33
11.9	Exit Output.....	33
11.10	Ready Output	33
11.11	Telephone Trouble Output	33
11.12	Late To Close Output	33
11.13	Device Fail Output	33
11.14	Sensor Reset Output.....	33
11.15	Closing Wait Output.....	34
11.16	Arm-Alarm Output	34
11.17	Supervisory Alarm Output	34
Output Information		35
12.1	Output Information.....	35
12.2	Output Number	35
12.3	Output Name	35
12.4	Output Real-Time Status	35
12.5	Serial Number	35
12.6	Supervision Time	35
12.7	Trip with Panel Bell Option.....	35
Output Groups		36
13.1	Output Groups.....	36
13.2	Group Number.....	36
13.3	Group Name	36
13.4	Output Number	36
Menu Display.....		37
14.1	Menu Display	37
14.2	Armed Status	37
14.3	Time	37
14.4	Arm/Disarm.....	37
Status List.....		38
15.1	Status List	38
15.2	Display Keypads	38
15.3	System Monitor Troubles	38
15.4	Fire Zones.....	38
15.5	Burglary Zones	39
15.6	Supervisory Zones	39

TABLE OF CONTENTS

15.7	Panic Zones.....	39
15.8	Emergency Zones	39
15.9	Auxiliary 1 Zones	39
15.10	Auxiliary 2 Zones	39
15.11	Communication Trouble.....	39
PC Log Reports.....		40
16.1	PC Log Reports.....	40
16.2	Communication Type.....	40
16.3	Net IP Address	40
16.4	Net Port	40
16.5	Arm and Disarm Reports	40
16.6	Zone Reports.....	40
16.7	User Command Reports.....	40
16.8	Door Access Reports	40
16.9	Supervisory Reports	41
16.10	PC Log Real-Time Status	41
Area Information		42
17.1	Area Information	42
17.2	Exit Delay.....	42
17.3	Burglary Bell Output.....	42
17.4	Opening/Closing Reports	42
17.5	Closing Check.....	43
17.6	Closing Code	43
17.7	Any Bypass	43
17.8	Area Schedules.....	43
17.9	Area Number	43
17.9.1	All/Perimeter Programming.....	43
17.9.2	Home/Sleep/Away Programming.....	43
17.10	Area Name.....	44
17.11	Account Number	44
17.12	Automatic Arming	44
17.13	Bad Zones	44
17.14	Automatic Disarming.....	44
17.15	Armed Output Number.....	45
17.16	Late Output Number	45
17.17	Late Arm Delay.....	45
17.18	Common Area	45
17.19	Arm First Area	45
Zone Information.....		46
18.1	Zone Information.....	46
18.2	Zone Number	46
18.3	Zone Name	46
18.4	Zone Type	47
18.5	Area Assignment.....	47
18.6	Fire Bell Output	47
18.7	Arming Zone Area Assignment.....	48
18.8	Style	48
18.9	Next Zone	49
18.10	Wireless.....	49
18.10.1	Serial Number Entry.....	49
18.10.2	Contact	49
18.10.3	Supervision Time	50
18.10.4	LED Operation	50
18.10.5	Disarm/Disable	50
18.10.6	PIR Pulse Count.....	50
18.10.7	PIR Sensitivity	50
18.10.8	Next Zone	50
18.11.1	Key Fob User Number	51
18.11.2	Key Fob Serial Number.....	51
18.11.3	Key Fob Supervision Time	51
18.11.4	Number of Key Fob Buttons	51
18.11.5	Key Fob Button Selection (Four Buttons).....	51

TABLE OF CONTENTS

18.11.6	Key Fob Button Selection (Two Buttons)	51
18.11.7	Button Action	52
18.11.8	Button Press Time	52
18.11.9	Arm/Disarm Area Selection	52
18.11.10	Output Number	53
18.11.11	Output Action	53
18.11.12	Next Zone	53
18.12	Alarm Action	54
18.13	Disarmed Open	54
18.14	Report to Transmit	54
18.15	Output Number	54
18.16	Output Action	55
18.17	Swinger Bypass	55
18.18	Prewarn Keypad Addresses	55
18.19	Entry Delay	55
18.20	Zone Retard Delay	55
18.21	Presignal Keypad Addresses	55
18.22	Fast Response	56
18.23	Cross Zone	56
18.24	Priority	56
18.25	Fire Panel Slave Input	56
18.26	Area Follower	56
18.27	Zone Real-Time Status	56
18.28	Zone Audit Days	56
18.29	Report with Account Number for Area	56
Stop	57
19.1	Stop	57
Set Lockout Code	57
20.1	Set Lockout Code	57
Appendix	58
21.1	False Alarm Reduction	58
	System Recently Armed report	58
21.2	Diagnostics function	58
	Test LX-Bus	58
	Zone Finder	58
	Zone State	58
	LX-Bus Status	58
	MAC Address	59
	Serial Number	59
	Current Flash	59
	Communication Status	59
	Cellular Signal	59
	Email Status	59
	Exiting the Diagnostics program	60
21.3	Using the 984 Command Function	60
21.4	Using the Walk Test	61
	Walk Test	61
	Zone Types	61
	Bell Action	61
	Trip Counter For Walk Test	61
	Test End Warning	62
	Failed Zones Display	62
21.5	Keypad Speaker Operation	62
21.6	Cross Zoning	62
21.7	Events Manager	63
21.8	User Profiles	63
21.9	User Profiles Record	63
21.10	Zone Type Descriptions	64
21.11	Zone Type Specifications	65
21.11.1	Keypad Bus Zone Type Defaults	65
21.11.2	LX-Bus Zone Type Defaults	66
21.12	Common Keypad Messages	67
21.13	Area Account Number Messages	68
Revisions to This Document	69
	Listings and Approvals	70

Introduction

1.1 Before you Begin

This guide provides programming information for the DMP XR100 and XR100N Command Processor™ Panel. After this Introduction, the remaining sections describe the functions of each programming menu item along with the available options. Before starting to program, we recommend that you read through the contents of this guide. The information contained here allows you to quickly learn the programming options and operational capabilities of the XR100 and XR100N panels.

In addition to this guide, you should also read and be familiar with the following XR100 Series Canadian documents:

- XR100 Series Canadian Installation Guide (LT-0899CAN)
- XR100 Series Canadian Programming Sheet (LT-0897CAN)
- XR500/XR100 Security Command® User's Guide (LT-0683CAN)

Internal Programmer

The panel contains all of its programming information in an on-board processor and does not require an external programmer. You can perform all programming tasks through a 32-character DMP alphanumeric keypad set to address one.

Programming Information Sheet

Included with each panel are the Programming Information Sheets. These list the various programming prompts and available options for programming the panel. Before starting to program, we recommend you completely fill out each sheet with the programming options you intend to enter into the panel.

Having completed programming sheets available before entering data helps prevent errors and can shorten the time you spend programming. Completed sheets also provide you with an accurate panel program record you can keep on file for future system service or expansion. The remainder of this Introduction provides instructions for starting and ending a programming session using the alphanumeric keypad.

1.2 Getting Started

Ground Yourself Before Handling the Panel! Touch any grounded metal, such as the enclosure, before touching the panel to discharge static.

Remove All Power From the Panel! Remove all AC and Battery power from the panel before installing or connecting any modules, cards, or wires to the panel.



Before starting to program the XR100 Series Canadian panel, make sure the panel is properly grounded and AC and battery power is applied to the appropriate panel terminals. All wiring connections and grounding instructions are detailed in the XR100 Series Canadian Installation Guide (LT-0899CAN).

Program from any Keypad Address or Wireless Keypad

You can program the XR100 Series Canadian panel from any 32-character wireless keypad or hardwired keypad connected to the panel's keypad data bus. See the XR100 Installation Guide for keypad addressing and installation information for hardwired keypads.

Wireless Keypads can be used for panel programming after being programmed in the panel manually or by using the Wireless Keypad Association operation.

To enable association operation in the keypad, access the Installer Options Menu (3577 (INST)) and select RF Survey. The keypad logo LEDs turn on Red until association is successful.

To enable association operation in the XR100 Series Canadian panel, reset the panel 3 times within 12 seconds. Allow the panel's keypad bus Transmit/Receive LEDs to turn back on between each reset.

For 60 seconds the panel listens for wireless keypads that are in the Installer Options Menu and have not been programmed, or associated into another panel. Those keypads are assigned to the first open device position automatically based upon the order in which they are detected. The keypad logo turns Green to indicate it has been associated with the panel. See the 9000 Series Wireless Keypad Installation Guide (LT-1107) for additional information.

Accessing the Programmer

1. Momentarily place the Reset jumper over both of the J16 pins to reset the panel.
2. Enter the code 6653 (PROG) and press COMMAND.
3. The keypad displays: **PROGRAMMER.**

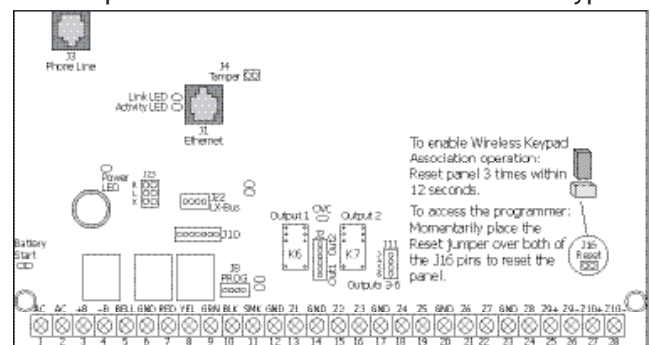

Figure 1: XR100 Series Canadian Panel Showing Reset

INTRODUCTION

1.3 Programmer Operation

There are 18 programming sections to choose from:

Programming Item	Section in This Manual	Programming Item	Section in This Manual
Initialization	2	Output Information	12
Communication	3	Output Groups	13
Network Options	4	Menu Display	14
Messaging Setup	5	Status List	15
Device Setup	6	PC Log Reports	16
Remote Options	7	Area Information	17
System Reports	8	Zone Information	18
System Options	9	Stop	19
Bell Options	10	Set Lockout Code	20
Output Options	11		

To choose a section for programming, press any top row Select key when the keypad displays the name of that section. Sections 2 through 19 contain detailed instructions for each programming step.

1.4 Programmer Lockout Codes

The panel allows you to enter the programming function without entering a lockout code using steps 1 to 4 listed in Getting Started. We recommend, however, that you install a Lockout Code to restrict programming to only those persons your company authorizes. You can do this by using the **SET LOCKOUT CODE** feature in the Programmer. The Lockout Code restricts any unauthorized panel programming.

After resetting the panel and entering the code 6653, the keypad displays **PROGRAMMER**. Press **COMMAND** to advance through the programming sections until **SET LOCKOUT CODE** displays (after **STOP**). Press any top row Select key. The keypad displays **ENTER CODE: - .** Enter a 3 to 5 digit Programmer Lockout Code and press **COMMAND**. The keypad displays **ENTER AGAIN** followed by **ENTER CODE: -.** Enter the same 3 to 5 digit code a second time and press **COMMAND**. The keypad displays **CODE CHANGED**.

Note: The panel will not accept a 5-digit Lockout Code higher than 65535.

Before accessing programmer functions enter the new code number.

Write the Lockout Code number down and keep it in a secure place with access limited to authorized persons only. Lost Lockout Codes require the panel to be sent back to DMP for repair. You may cancel a Lockout Code by entering 00000 at the Set Lockout Code command.

1.5 Reset Timeout

The panel has a feature that requires you to enter the Programmer within 30 minutes of resetting the panel. After 30 minutes, if you attempt to program by entering the 6653 (PROG) code, the keypad displays: **RESET PANEL**. You must reset the panel and enter the program code then begin programming within the next 30 minutes.

If you are already in the Programmer and do not press any keys on the programming keypad for 30 minutes, the panel terminates programming. All data entered up to that time is Not saved unless you run the Stop routine.

Note: Use the Stop routine to exit panel Programming. Ensure the keypad displays “**SAVING PROGRAM**” to save all programming changes entered.

1.6 Power Up

When the XR100 Series Canadian panel is powered up after an AC power failure, any zone transitions are not recognized for 60 seconds. Normal zone processing resumes at the end of the 60 seconds.

1.7 Keypads

DMP offers multiple keypads in a variety of styles. All DMP keypads provide the same programming capabilities. Each keypad and its operation are shown and described in the following sections.

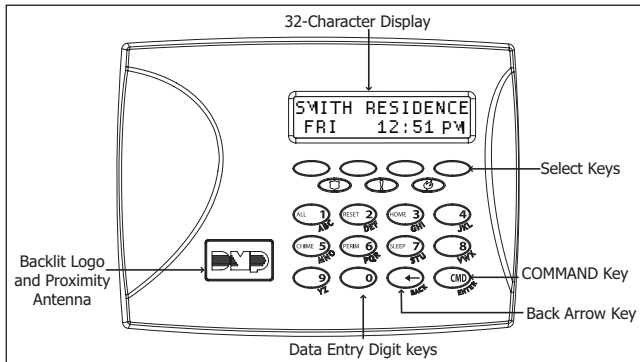

Figure 3: Wireless Keypad

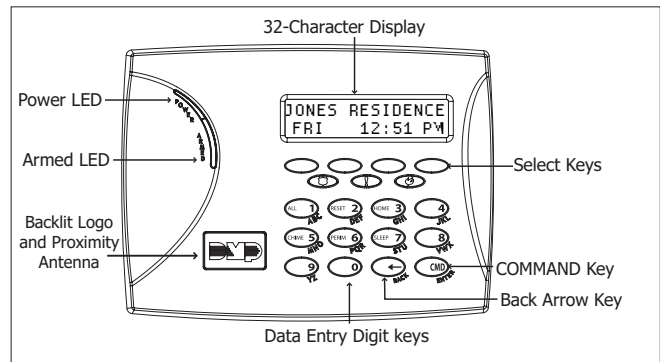

Figure 4: Thinline/Aqualite Keypad

1.8 Special Keys

The following special keys/areas are common to all DMP keypads.

COMMAND (CMD) Key

Pressing the COMMAND key allows you to go forward through the programming menu and through each step of a programming section. As you go through the programming, the keypad display shows any current programming already stored in the panel memory. If no change is required for a prompt, press the COMMAND key to advance to the next step.

The COMMAND key is also used to enter information into the panel's memory such as phone numbers or zone names. Press the COMMAND key after entering information.

Back Arrow (←) Key

Use the Back Arrow key to back up one step while programming. The Back Arrow key is also used when an error is made while entering information. Press the Back Arrow key once to erase the last character entered.

Select Keys/Areas

The top row of keys are called the Select keys on Security Command, Thinline, and Aqualite keypads. Each time you need to press a Select key, the keypad displays the function or options above one of the keys or in the Select Area. Displaying choices above individual Select keys or in Select Areas allows them to be used for many different applications. For example, you can enter AM or PM when programming the automatic test time or answer YES or NO for a system option.

During programming, the Select keys/areas also allow you to change information currently in panel memory by pressing the appropriate Select key/area under or on the display. You then enter the new information using the keypad data entry digit keys.

When there are more than four response options available, press the COMMAND key to display the next one to four options. Pressing the Back Arrow key allows you to review the previous four choices.

The Select keys/areas are also used for choosing a section from the programming menu. Press any Select key or touch the Select Area when the programming section name you want displays.

Note: On Wireless, Thinline and Aqualite keypads, when instructed to press the first Select key, press the far left Select key; the second Select key is the second from the left; third Select key is second from the right; and the fourth Select key is the far right key. See Figures 5.

1.9 Entering Alpha Characters

Some options during programming require you to enter alpha characters. To enter an alpha character, press or touch the key that has that letter written below it. The keypad displays the number digit of the key. Next, press the Select key/area that corresponds to the location of the letter under the key. Pressing a different Select key/area changes the letter. When another digit key is pressed, the last letter displayed is retained and the process starts over.

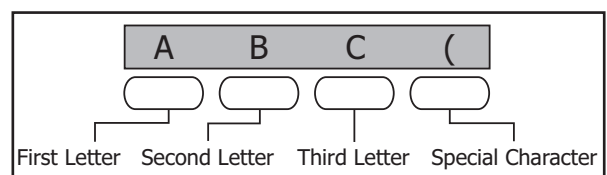

Figure 5: Thinline/Aqualite/Wireless Select Keys

1.10 Entering Non-Alpha Characters

To enter a space in an alpha entry, press the 9 digit key followed by the third Select key/area. The three characters on the 9 digit key are Y, Z, and space. You can also enter the following characters: - (dash), . (period), * (asterisk), and # (pound sign) using the 0 (zero) key and the four Select keys/areas from left to right. For example, to enter a - (dash), press the 0 (zero) key and then the left Select key/area. A dash now appears in the keypad display. The table below shows the character locations for DMP keypads.

Key Number	Select Key 1	Select Key 2	Select Key 3	Select Key 4
1	A	B	C	(
2	D	E	F)
3	G	H	I	!
4	J	K	L	?
5	M	N	O	/
6	P	Q	R	&
7	S	T	U	@
8	V	W	X	,
9	Y	Z	space	_
0	-	.	*	#

1.11 Keypad Displays Current Programming

Each programming prompt displayed at the keypad shows the currently selected option in the panel memory. These options are either shown as a number, a blank, or a **NO** or **YES**. To change a number or blank to a new number, press any top row Select key or touch any Select Area. The current option is replaced with a dash. Press the number(s) on the keypad you want to enter as the new number for that prompt. It is not necessary to enter numbers with leading zeros. The panel automatically right justifies the number when you press the **COMMAND** key.

To change a programming prompt that requires a **NO** or **YES** response, press the Select key or touch the Select Area for the response not selected. See Figure 12.

For example, if the current prompt is selected as **YES** and you want to change it to **NO**, on Security Command, Thinline, or Aqualite keypads press the third top row Select key. The display changes to **NO**. Press the **COMMAND** key to display the next prompt.

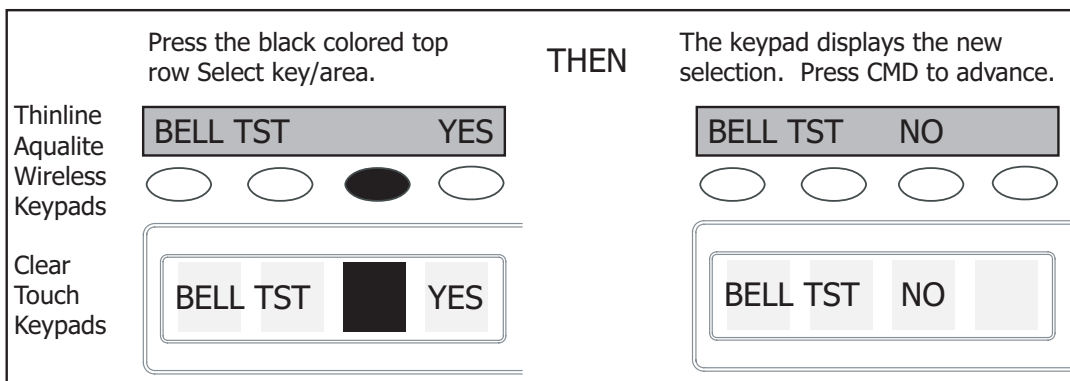

Figure 6: Changing the Current Programming Option

1.12 Asterisks in Programming

Asterisks display next to a programming option that is already selected. As shown in the example, options that are selected to display the current programming selection have an asterisk next to the number. Those that are not selected simply display the number. In the Devices example, keypads 3, 6, and 8 are not selected. In the Areas example, areas 3, 6, and 8 are not selected. In both examples the numbers with asterisks are selected.

Devices				Areas			
*1	*2	3	*4	*1	*2	3	*4
*5	6	*7	8	*5	6	*7	8

To select or deselect a number, simply enter the number using the digit keys on the keypad. This same scheme is used when viewing the panel armed status and other programming and operational functions. Remember to press the COMMAND key to display the rest of the device or area numbers.

Initialization

NOTE: WHEN ANY PANEL PROGRAMMING IS CHANGED, THE STOP ROUTINE MUST BE RUN AND 'SAVING PROGRAM' MUST DISPLAY ON THE KEYPAD IN ORDER TO SAVE THE PROGRAMMING CHANGES. SEE SECTION 17.1.

2.1 INITIALIZATION Initialization

This function allows you to clear selected parts of the panel program back to the factory defaults in preparation for system programming. Run the initialization function on all new installations.

For each section of the panel program you can initialize, a NO or YES option is provided.

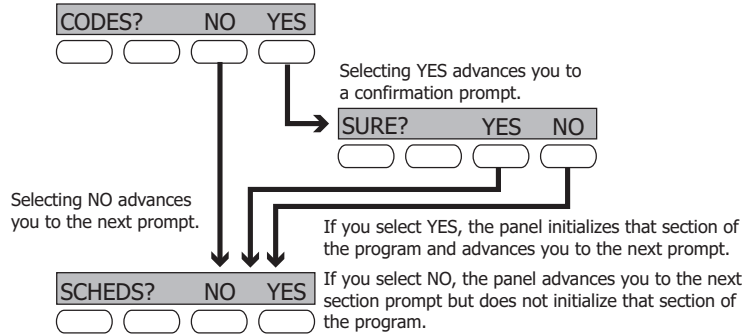

2.2 INIT ALL? NO YES SURE? YES NO Clear All Memory

NO - Leaves existing programming intact then displays Clear All Codes.

YES - Clears all memory then displays Reset Panel. Reset the panel by shorting J16 and re-enter programming mode to continue.

2.3 CODES? NO YES SURE? YES NO Clear All Codes

NO - Leaves existing codes intact.

YES - Clears the user code and user profile memory and assigns user code number 99 to the highest user position.

Note: The user name for the default user code is created using the current programmed primary user language.

2.4 SCHEDULES? NO YES SURE? YES NO Clear All Schedules

NO - Leaves existing schedules intact.

YES - Clears all shift, and output schedules.

2.5 EVENTS? NO YES SURE? YES NO Clear Display Events Memory

NO - Leaves existing event memory intact.

YES - Clears the events memory.

2.6 ZONES? NO YES SURE? YES NO Clear Zone Information

NO - Leaves existing zone information intact.

YES - Clears the zone information for all zones. All zones are marked * UNUSED * and must be renamed before being able to display on any system keypad.

2.7 AREAS? NO YES SURE? YES NO Clear Area Information

NO - Leaves existing area information intact.

YES - Clears the area information for all areas. All areas are marked * UNUSED * and must be renamed before being able to display on any system keypad.

2.8 OUTPUTS? NO YES SURE? YES NO Clear Output Information

NO - Leaves existing output information intact.

YES - Clears all programmed Output names and any output cutoff assignment.

2.9

COM/RMT?	NO	YES
----------	----	-----

Clear Communication and Remote Options

SURE?	YES	NO
-------	-----	----

NO - Leaves existing communication and remote options intact.
YES - Clears communication and remote options programming to factory defaults.

2.10

DEFAULTS	NO	YES
----------	----	-----

Set to Factory Defaults

SURE?	YES	NO
-------	-----	----

NO - Leaves existing panel programming intact.
YES - Sets the remainder of the panel programming back to the factory defaults.
Note: Sets the Programming and User language to English.

Communication

- 3.1** **COMMUNICATION** **Communication**
Configure the communication options for the panel. The information you program varies with the Communication Type you select.
- 3.2** **ACCOUNT NO: 12345** **Account Number**
The Account Number is a 1 to 5 digit number used to identify which panel is sending a message. Enter the account number sent to the SCS-1R Receiver. Messages may be sent to a central station or via PC Log Reports to a PC. The default is 12345.
NET, CELL, and DD - The range of valid account numbers for a panel is 1 to 65535. For accounts of four digits or less, do not enter leading zeros.
CID - Choose an account number between 1 and 9999.
- 3.3** **XMIT DELAY: 30** **Transmit Delay**
Enter the number of seconds (15 to 45) the panel waits before sending burglary zones (Night, Day, or Exit) reports to the receiver. Other zone type reports are sent immediately. Alarm bells and relay outputs are not delayed during this period. Program Burglary Outputs for pulsed or steady, and set Abort Reports to YES if Opening and Closing reports are not being sent. Enter 0 (zero) to disable this function. The default is 30.

If the area where the alarm occurred is disarmed during the Transmit Delay time, only an Abort Report (S45) message is sent to the receiver. If the area where the alarm occurred is disarmed after the alarm message is sent to the receiver but before the Bell Cutoff time expires even if the alarm was silenced, an Alarm Cancelled (S49) message is sent. Otherwise the alarm is sent at the end of the delay. The Alarm Cancelled report cannot be disabled.

Note: For Commercial Burglary Installations, the combined Transmit Delay (Abort Window) and Entry Delay must not exceed one (1) minute.
- 3.4** **PATH: -** **Communication Path**
Up to eight communication paths may be programmed. Each path is designated as a primary or backup communication route. Path 1 is always Primary but other paths may be programmed as additional primary or backup.

Each primary path establishes a new path group. A path group is made up of the primary path and its subsequent backup paths. Typical communication takes place on the primary path with backup paths being used only when the primary path fails or when the backup path is programmed to duplicate messages. There is no option to backup path 8.
- 3.5** **COMM TYPE: DD** **Communication Type**
Specifies the communication method the panel uses on this path to report system events to DMP SCS-1R Receivers or non-DMP receivers. Default is DD for Path 1, and NONE for Path 2-8.

NONE DD NET CID **NONE** - For local systems. Selecting NONE ends communication programming.
DD - Digital Dialer communications to a DMP SCS-1R Receiver.
NET - Network communication using the panel onboard network connection. The DMP Network/Output reporting format is transmitted over a data network to the SCS-1R Receiver.
CID - This option allows the panel to communicate to non-DMP receivers using the Contact ID format.
CELL - This option allows communication over the GPRS network using digital cellular technology with the CellCom Series Digital Cellular Communicator.

- 3.6** PATH TYPE: **BACKUP** **Path Type**
PRIMARY **BACKUP** The Path Type defines if the path is Primary or Backup. Because Path 1 is Primary, this prompt only displays for paths 2-8. Default is Backup.
Note: If the Primary Communication Type is CELL, then the backup Communication Type can only be NET.
- 3.7** TEST RPT: **YES** **Test Report**
NO YES DEFER Test Report determines if test reports are sent on this path. Reports are sent according to the programming in Test Frequency and Test Time. Default is Yes. Select YES to allow the programmed test report to be sent on the path currently being programmed.
 Select DEFER to not send a test report if the panel communicates any message to the receiver within the time set in Test Frequency. Select NO to not send test reports on this path.
- 3.8** TEST FREQ: **1 DY** **Test Frequency**
 Test Frequency determines the frequency of the test report. Enter a number from 1 to 60 and select DY (Day) or HR (Hour) by pressing the far right top row select key. Default is 1 Day.
- 3.9** TEST DAY: **SUN** **Test Day**
 Use this option to set the day of the Test Report. This prompt appears only when Test Report is Yes, Test Frequency is Day and a multiple of seven. Press the COMMAND key to display the first four days of the week. Press the COMMAND key to display the last three days. Select the day of the week to send the test report. Default is Sunday.
- 3.10** TEST TIME:
0:00 AM **Test Time**
 Use this option to select the time of day for Test Reports. Select the hour, minute and AM/PM. Enter 0:00 AM to disable this feature. Default is 0:00 AM.
- 3.11** CHECKIN: NO YES **Check In**
 This option displays if the COMM TYPE is NET, or CELL. Check-in reports are a method of supervising the panel for communication with the receiver. For NET the default is YES. For CELL, the default is NO.
CHECKIN:
NO YES RND ADPT Select RND (Random) for the panel to check-in at random times from 6 to 60 minutes when all areas are disarmed. If any area is armed a check-in is sent every 6 minutes. Select ADPT (Adaptive) for a backup path to adapt to the check-in programming from this groups primary path if the primary path becomes unavailable. Check-in programming includes Check-in and Fail Time.
CHECKIN:
ADP3 Select ADP3 (Adaptive 3) for a backup path to adapt using a 3 minute Check-in and Fail Time if the primary path becomes unavailable. This option also indicates a Communication Trouble (S10) if the cell tower is unavailable for 3 minutes.
CHECKIN MINS: **200** When YES is selected, enter the number of minutes between check-in reports, from 2 to 240 for NET or 3 to 240 for CELL, when the panel is armed or disarmed. For CELL, the default is 0. For NET the default is 200.
- 3.12** FAIL TIME: **240** **Fail Time**
 This option displays if CHECKIN is set to YES. Entering a FAIL TIME allows the receiver to miss multiple check-ins before logging that the panel is missing. The maximum fail time is 240 minutes. For example, if CHECKIN is 10 and FAIL TIME is 30, the receiver only indicates a Panel Not Responding after 30 minutes. The FAIL TIME must be equal to or greater than the CHECKIN time. Default is 0 for CELL. Default is 240 for NET.
- 3.13** RECEIVER IP **Receiver IP**
 This option displays only if the Communication Type is NET or CELL. Enter the Receiver IP address where the panel sends network messages. The Receiver IP Address must be unique and cannot be duplicated on the network. Enter all 12 digits and leave out the periods. For example, enter IP address 192.168.0.250 as 192168000250. The periods display automatically.

3.14 **Receiver Port**

Enter the receiver port number. Valid range is 1 to 65,535. Default is 2001.

3.15 **First Telephone Number**

This option displays only if the Communication Type is DD or CID.

This is the first number the panel dials when sending reports to the receiver. Phone numbers can have two lines of 16 characters each to equal up to 32 characters.

Enter P to program a three-second pause in the dialing sequence. The P character counts as part of the 32 allowable characters.

Enter R as the first character for rotary (pulse) phone function. The R character counts as part of the 32 allowable characters.

Call Waiting: You can place the “* 7 0 P” (Star, Seven, Zero, Pause) in the telephone number first position to cancel Call Waiting. For example, program NET with second line DD and phone number *70P555-1212, and you have NET with Call Waiting cancelled on the second line.



Caution: A call waiting cancel programmed on a non-call waiting telephone line would prevent communication to the central station.

3.16 **Second Telephone Number**

The panel dials the second number when two successive tries using the first number fail. If the panel cannot reach the receiver after two attempts using the second number, it returns to the first number and makes two additional attempts. A total of ten dialing attempts are made using the first and second phone numbers.

Each number can be up to 32 characters in length including any P or R characters entered for pause or rotary connections or call waiting cancel option.

Should all ten attempts fail, the panel continues to attempt sending the message using the next programmed path. If all programmed communication paths fail, the panel clears the communication buffer and makes one communication attempt each hour to send a TRANSMIT FAILED (S87) report to the receiver. Access the User Menu Display Events feature to view the report information not sent to the receiver or download the report with DMP Remote Link™ software.

3.17 **Advanced Programming**

Select Yes to enter the Advanced Programming menu for the communication path currently being programmed.

3.18 **First GPRS APN**

Enter the first APN (Access Point Name). This allows an access point for cellular communication and is used to connect to a DNS network. The APN may contain two lines of 16 characters to equal 32 characters. Default is set to NMRX.CA.APN.

Second GPRS APN

Enter the second APN (Access Point Name). This works as a backup in case the first APN fails. The APN may contain two lines of 16 characters to equal 32 character Default is set to INTERNET.COM.

3.19 **Fail Test Hours**

This option sets the frequency for a Backup or Adaptive path to send a test report when the closest previous path fails within its path group.

For example, if a backup path is programmed to send a weekly test report and the Fail Test Frequency is set to 2 hours, when the previous path fails within its group, the backup path starts sending a test every 2 hours until the previous path restores. If Fail Test Frequency is set to 0, test reports are sent only according to Test Report programming. Range is 0 to 24 hours. Default is 0.

- 3.20** **Protocol**
 This option displays only when Communication Type is NET.
 Select TCP to communicate over the network using TCP protocol. Select UDP to communicate using UDP protocol. Default is TCP.
- 3.21** **Retry Seconds**
 This option displays for NET Communication Types.
 Enter the number of seconds (between 6 and 15) the panel should wait before retrying to send a message to the receiver if an acknowledgment was not received. The panel retries as many times as possible for a period of one minute before sending a network trouble message. For example, if retry time is set to 15, the panel retries four times. The default Retry Time is 6 seconds.
Note: If TCP is enabled, the minimum Retry Time programmed is 6 seconds.
- 3.22** **Substitution Code**
 This option displays when the Communication Type is NET, or CELL. The Panel Substitution Code increases the level of security by helping to ensure that the panel sending the message to the receiver has not been substituted by another panel. The default is NO.
 Select YES to send a substitution code with every message.
 Select SHARED (SHR) to use the same substitution code as operating in the previous path.
- 3.23** **893A**
 This option displays when the Communication Type is DD or CID.
 The 893A option allows reports to be sent to the receiver on a second DD line using the 893A module. Default is No.
 When using this option, Test Report messages (S07 Automatic Recall Test or S88 Unrestored System Recall Test) will be sent to the receiver at the frequency programmed in Test Frequency, alternating between the first and second phone line.
 For example, a DD path with an 893A module set for daily test report frequency will send a test report through phone line 1 one day and phone line 2 the next day.
 If 893A option is set to YES, enter up to a 3 digit prefix to be dialed before the second phone number. If no prefix is entered, the second phone number is dialed as originally entered.
- 3.24** **Alarm Switch**
 This prompt displays for DD or CID Communication Types.
 Enter the number of attempts to send an alarm message before switching to the next path. Range is from 1 to 10. All non-alarm messages will be sent for 10 attempts on the dialer before a switch is initiated. If the path immediately following this channel is not a backup path, this option has no effect. Default is 1.
- 3.25** **Duplicate Alarms**
 This prompt displays for BACKUP paths. If Yes is selected, the current backup path duplicates all alarms occurring on its group primary path. Default is No.
- 3.26** **Alarm Reports**
 This prompt displays when the Path Type is Primary. All backup paths within the group follow the same programming for Alarm Reports. Default is Yes.
 When YES is selected, the following reports are sent to the receiver for all zone types:
 • Alarm • Bypass • Reset • Restore
 When FIRE is selected, the following reports are sent for Fire, Fire Verify and Supervisory Zones:
 • Alarm • Bypass • Reset • Restore

3.27

SPV/TRBL YES

Supervisory/Trouble Reports

This prompt displays when the Path Type is Primary. All backup paths within the group follow the same programming for Supervisory/Trouble Reports. Default is Yes.

NO YES FIRE

When YES is selected, the following reports are sent for all zone types:

- Trouble
- Low Battery
- Missing
- Fault
- Restorals
- System Troubles
- System Restoral

When FIRE is selected, the following reports are sent for Fire, Fire Verify, and Supervisory Zones:

- Trouble
- Low Battery
- Missing
- Fault
- Restorals
- System Troubles
- System Restoral

Serviceman reports are sent regardless of the selection made for Supervisory/Trouble reports.

3.28

O/C USER NO YES

Opening/Closing and User Reports

This prompt displays when the Path Type is Primary. All backup paths within the group follow the same programming for Opening/Closing and User Reports. Default is Yes.

When YES is selected, the following reports by user are sent to this receiver.

- Opening
- Closing
- Bypass
- Reset
- Code changes (including adding, deleting, changing)
- Schedule changes (temporary, permanent, shift)
- Holiday date changes

3.29

DOOR ACS YES

Door Access Report

This prompt displays when the Path Type is Primary. All backup paths within the group follow the same programming for Door Access Reports. Default is Deny.

NO YES DENY

Select YES to enable Door Access Granted and Denied reports to this receiver whenever a door access is granted to a user. The Door Access Granted report is only sent if the keypad number has also been selected in Access Keypads under the **SYSTEM REPORTS** programming.

Select DENY to enable Door Access Denied reports only to this receiver when a door access is denied to a user.

3.30

SEND COMM TRBL:

Send Communication Trouble

NO YES

This prompt displays for each path and determines if and how communication trouble on the path is sent to the receiver. A trouble message indicates both the path number and communication type that failed. Default is Yes.

3.31

SEND PATH INFO:

Send Path Information

NO YES

This prompt displays for each path and if YES, each panel message includes path information such as path number, communication type, and path type. Default is No.

Network Options (XR100N only)

Network Options are provided to define the network configuration for the panel. This information will be used during communication of messages via network or email.

Note: IP addresses and port numbers may need to be assigned by the network administrator. When entering an IP, Gateway, or Subnet Mask address be sure to enter all 12 digits and leave out the periods. For example, IP address 192.168.000.250 is entered as 192168000250.

- 4.1** DHCP **NO** **YES** **DHCP Mode Enabled**
 If the panel uses a dynamic IP address select YES. When set to YES, the panel operates using DHCP and does not use the Local IP Address number. When the DHCP option is set to NO, the panel uses the IP address entered in Local IP Address. The default value for DHCP mode is YES.
- 4.2** **Local IP Address**
 Enter the local IP address. The Local IP Address must be unique and cannot be duplicated. The default local IP address is 192.168.0.250.
- 4.3** **Gateway Address**
 Enter the local gateway address. The Gateway IP Address is needed to exit your local network. The default gateway address is 192.168.0.1.
- 4.4** **Subnet Mask**
 Enter the local subnet mask assigned to the panel. The default subnet mask address is 255.255.255.000.
- 4.5** **DNS Server**
 Enter the IP address of the DNS (Domain Name System) used by the panel to resolve domain names into IP addresses. The default address is 192.168.0.1.
- 4.6** **734N Listen Port**
 Enter the port number that the 734N/734N-WiFi will use to send communication to the panel. This must be the same port that is programmed in Panel IP Port within the 734N Communication programming menu.
- 4.7** **734/734N Passphrase**
 Enter an 8 to 16-character Passphrase to encrypt communication with the 734N/734N-WiFi module. The 734N Passphrase must match the 734N Passphrase entered in Communication programming of the 734N. The Passphrase is blank by default.
Note: A passphrase is required for operation.

Messaging Setup

- 5.1** MESSAGING SETUP **Messaging Setup**
- This section allows you to enter the information needed to receive messages directly from the panel via email and In Touch™ SMS Text using Network or Cellular communication. All of the name and password options below allow up to 32 lowercase characters to be entered. The Destination addresses allow up to 48 characters to be entered. System Name is displayed with initial caps.
- The transmitted messages are:
- Zone Alarms by Zone Name
 - Zone Troubles by Zone Name
 - Zone Bypass by User
 - Arming (Closings) by User
 - Disarming (Openings) by User
 - Late to Close
 - AC Power Trouble and Restoral
 - System Low Battery
 - Ambush
 - Abort, Cancel and Alarm Verified by User
 - Check-in by user
- 5.2** ENABLE MESSAGING **Enable Messaging**
- NO YES Select YES to allow the panel to send messages to three programmed destinations. Default is NO.
- 5.3** SYSTEM NAME **System Name**
- Enter a unique name for the panel. The panel name is used as the sender of the message. The text entered is displayed with initial caps. If this field is left blank, the panel account number is sent.
- 5.4** DESTINATION 1 **Destination 1**
- Enter the first email address or cell phone number where messages will be sent. The message can be sent to any device (computer, cell phone, PDA) as long as a valid email address or cell phone number is entered. When entering email addresses, press the 7 digit key followed by the fourth Select Key to add the @ symbol and the 9 digit key followed by the fourth Select Key to add the _ symbol. See the Entering Non-Alpha Characters section for additional symbols.
- Note:** Mail servers that require Transport Layer Security (TLS) encryption are not supported by the XR100 Series.
- 5.5** DESTINATION 1 USER NUMBER: 0 **Destination 1 User Number**
- If Destination 1 is a 10-digit cellular number, enter a user's user number from this account. This option is used when sending commands such as arming or disarming back to the panel using In Touch™ SMS Text from the same cell phone or PDA. The user number must have the authority to perform the commands as if it occurred at the keypad. In Touch™ SMS Text command operation is available in XR500 Series panels using version 205 or higher. Entering 0 (zero) disables this option. Default is 0.
- 5.6** DESTINATION 2 **Destination 2**
- Enter the second destination email address or cell phone number.
- 5.7** DESTINATION 2 USER NUMBER: 0 **Destination 2 User Number**
- If Destination 2 is a cellular number, enter the user's User Number for arming/disarming authorization.
- 5.8** DESTINATION 3 **Destination 3**
- Enter the third destination email address or cell phone number.

- 5.9** **Destination 3 User Number**
 If Destination 3 is a cellular number, enter the user's User Number for arming/disarming authorization.
- 5.10**
 Email Communication Type
 Choosing NET sends email messages over the network. Choosing CELL sends email messages via cellular communication. Default is NET. This prompt displays if any destination above is an email address and the panel is a network panel (has an Ethernet connector).
- 5.11** **O/C Email**
 Select YES to allow the panel to send Opening and Closing reports via email. Default is NO. This prompt displays if any destination above is an email address.
- 5.12** **O/C SMS**
 Select YES to allow the panel to send Opening and Closing messages to a cell phone via SMS protocol. Default is NO. This prompt displays if any destination above is a cell phone number.
- 5.13** **Monthly Limit**
 This option displays if any programmed destination is a cell phone number using NET or CELL communication or an email address using CELL communication. If all destinations are email addresses using NET communication, this option does not display. This number limits the monthly incoming and outgoing SMS messages allowed to be sent or received by the panel.
 A panel event that causes messages to be sent to destination cell phone numbers or destination email addresses is counted towards the panel's monthly limit. For example, if an alarm message is sent to a cell phone number and an email address using CELL communication, a total of 2 messages are counted towards the monthly limit for the panel. SMS messages sent from a cell phone to the panel, including status requests and In Touch™ SMS Text messaging commands, also count toward the monthly limit. The limit is reset at midnight on the 14th of every month. Range is from 0 to 999. When 0 is entered, there is no limit on the number of messages able to be sent or received by the panel. Default is 0.
Note: The SecureCom Wireless text plan selected for the panel should match or exceed the programmed Monthly Limit.
 The remaining options only appear if email messaging has been selected to be sent via network. The options allow the email server to be selected by the installing dealer. Typically this is the email service provided by the installing dealer. This allows opportunity for additional services to be provided to the end user.
- 5.10**
 SMTP Server
 Enter the SMTP (Simple Mail Transfer Protocol) Server name. The SMTP email server is responsible for sending the email to its destination. An example SMTP email server name is: mail.somedomain.com. The domain should be the email server that provides email support for your alarm customers.
- 5.11** **SMTP Server Port**
 The SMTP server port number is the port that the panel uses to initiate a TCP connection with the email server. The default port is 25.
- 5.12**
 SMTP Username
 Most SMTP servers require a username to send email. This is sent to the SMTP server in conjunction with the SMTP Password to provide email authentication to the server.
- 5.13**
 SMTP Password
 Most SMTP servers require a password to send email. This is sent to the SMTP server in conjunction with the SMTP Username to provide email authentication to the server. Passwords display as lowercase.
- 5.14**
 From Email Address
 Enter the email address on file with the email service. This displays in the email message as the sender's address.

Device Setup

- 6.1** DEVICE SETUP **Device Setup**
 This section allows you to define the XR100 Series Canadian panel physical configuration. You can install and address up to eight **supervised** devices on the keypad data bus.
- 6.2** DEVICE NO:- **Device Number**
 Enter the device number of the keypad you are programming. The valid range is 1-8. If using a wireless keypad, program the device number in the Status List Auxiliary 1 Zones programming option to display wireless keypad troubles.
Note: After you program each option for the first keypad, repeat these programming steps for each additional keypad.
- 6.3** * UNUSED * **Device Name**
 A device name must be given to each device in the system. To add a device name, press any Select key. The default device name (DEVICE X) displays. Select COMMAND to accept the default name or press a Select key to enter a new name up to 32 alphanumeric characters. Press the COMMAND key.
 To remove a device from the system, delete the device name by pressing any Select key, then press the COMMAND key. The panel automatically programs the name as * UNUSED *.
- 6.4** TYPE: **KEYPAD**
DOOR KPD FI EXP **Device Type**
 This section allows you to select a device type for the selected device number.
DOOR - The device is an access control device and is either a keypad using door strike functions or a Wiegand Interface Module.
KEYPAD - The device is a keypad.
FIRE - The device is a 630F Remote Annunciator.
EXPANDER - The device is a Zone Expansion Module.
Note: The following options display based on device type selected:
- 6.5** DEVICE COMM TYPE
KPD-BUS **Device Communication Type**
 For a Device Type of DOOR, select KPD-BUS to communicate with the device on the keypad bus or select NETWORK to communicate with the device using a network connection. Default is KPD-BUS.
DEVICE COMM TYPE
KPD-BUS NETWORK
 For a Device Type of KEYPAD, select KPD-BUS to communicate with the device on the keypad bus or select WIRELESS to communicate with the device using a wireless connection. Default is KPD-BUS.
DEVICE COMM TYPE
KPD-BUS WIRELESS
- 6.6** WIRELESS? **NO** YES **Wireless**
 Select YES to use a wireless keypad. Select NO to use a wired keypad. Default is NO. You can install and address up to four wireless keypads.
- 6.6.1** SERIAL#: XXXXXXXX **Serial Number**
 Enter the eight-digit serial number found on the wireless keypad.
- 6.6.2** SUPRVSN TIME: **240** **Supervision Time**
 Press any top row key to select the supervision time required for the device. Press COMMAND to accept the default time. Default is 240 minutes.
SELECT MINUTES:
0 60 240
 Press the Select key under the required number of minutes. The device must check in at least once during this time or a missing condition is indicated for that device. Zero (0) indicates an unsupervised wireless keypad.
Note: When the panel is reset, panel is powered down and powered up, or programming is complete, the supervision timer restarts for all wireless keypads.
- 6.7** ACCESS AREAS:
1 2 3 4
5 6 7 8 **Access Areas**
 Press the COMMAND key to program Access Areas. To select an area, enter the area number using the digit keys on the keypad. When an area is selected, an asterisk appears next to the area number. Enter the number again to deselect the area. Refer to the Multiple Displays section at the beginning of this document.
 Users must have matching access area numbers assigned to their code to receive a door access at this device.

If you do not enter any area numbers, all users with Door Access authority receives a door access without regard to schedules. If the user code is programmed for Anti-Pass YES, then the user is logged into all matching areas. This user is not allowed to access these areas again until they have egressed the area. See Egress Areas. When all areas accessed by a door are armed, the door is locked by the panel.

Note: For an All/Perimeter, Home/Sleep/Away, or Home/Sleep/Away with Guest system, Access Areas should be left at factory default settings.

6.8

EGRESS AREAS:			
1	2	3	4
5	6	7	8

Egress Areas

Press the COMMAND key to program Egress Areas. To select an area, enter the area number using the digit keys on the keypad. When an area is selected, an asterisk appears next to the area number. Enter the number again to deselect the area. Refer to the Multiple Displays section at the beginning of this document.

Note: For an All/Perimeter, Home/Sleep/Away, or Home/Sleep/Away with Guest system, Egress Areas should be left at factory default settings.

Note: If an area is programmed as an access area, it cannot be programmed as an egress area and therefore does not display during Egress Areas programming.

Use this option to detect Anti-passback violations. Anti-passback requires a user to properly exit (egress) an area they have previously accessed. If users fail to exit through the proper card reader location they are not granted access on their next attempt. Users must have matching access area numbers assigned to their profile, to receive a door access at this device. If the user is programmed for Anti-Pass YES, then the user is logged out of all matching areas. This allows the user to again access the area. See Access Areas section.

If you do not enter any area numbers, all users with Door Access authority receives a door access without regard to schedules. If you are not using the Anti-Pass feature leave Egress Areas blank.

6.9

DISPLAY AREAS:			
*1	*2	*3	*4
*5	*6	*7	*8

Display Areas

Press the COMMAND key to program Display Areas. To select an area between 1 and 8, enter the area number using the keypad digit keys. When an area is selected, an asterisk appears next to the area number. Enter the number again to deselect the area. Default is all area numbers. Refer to the Multiple Displays section at the beginning of this document.

Display Areas allows the XR100 Series burglary activities to be segmented so that only specific area(s) and their associated operation appear at a particular keypad. Area number(s) selected in this field affect the way users interact with the system from this particular device. For example: Program Device 1 to show only the zone activities and armed status of Area 1.

Enter the area number(s) that this keypad is to display. This allows specific area control from specific keypads, as well as annunciation of zones assigned to those area(s). When Display Areas is left defaulted (all areas selected), Menu Display and Status List items determine whether zone alarms and troubles display at this device, regardless of area assignment. Also, all system areas may be armed and disarmed from this device.

Note: For an All/Perimeter or Home/Sleep/Away system, Display Areas should be left at factory default settings.

For Home/Sleep/Away with Guest arming systems, the Display Areas selection determines which system the keypad arms and disarms. With areas 1, 2 or 3 being the first areas selected, the keypad is assigned to the Main system. With area 4, 5 or 6 being the first areas selected, the keypad is assigned to the Guest system.

User Action Allowed

When an area(s) is selected, the following user actions are allowed:

- Arming or Disarming of the area(s) selected from the ARM or DISARM menu
- Alarm Silence for the area(s) selected
- Zone Bypass of zones assigned to the area(s) selected
- Zone Monitor of zone assigned to the area(s) selected
- Shift schedule changes allowed for the area(s) selected
- Closing Check Schedule Extend is allowed for the area(s) selected

- Door Schedules changes are allowed for devices that have a matching area(s) as defined in Device Access Areas
- Door On/Off Menu operation is allowed for devices that have a matching area(s) as defined in Device Access Areas

Note: The previous user actions also require the matching area(s) be programmed in User Profile: Arm/Disarm area(s).

Status Display Allowed

When an area(s) is chosen, the following displays are allowed:

- Armed Status of the selected area(s)
- Zone Alarms and troubles for burglary (NT, DY, EX, A1, A2) type zones assigned to the selected area(s)
- Late to Close status of the selected area(s)
- Zone Status (normal/fault) of zones that are assigned to the selected area(s)

Options and Actions Not Affected

The following options are not affected by the Display Areas operation. The User Code authority level controls access to these items.

- Sensor Reset Menu
 - System Test/Panic Test
 - Service Request
 - Fire Drill
 - Outputs On/Off Menu
 - User Profiles
 - Set System Time and Date
 - Display Events
 - System Status Menu
 - Forgive Anti-Passback
- 24-hour zones display at keypads based on Status List programming only

Note: A common area and its operations cannot be assigned to a specific keypad.

Display Areas example: When Device 1 has Display Areas set to 3, 5, and 8, it annunciates troubles and alarms only for zones assigned to those areas. When arming/disarming from Device 1, only areas 3, 5, and 8 may be armed/disarmed, even when the User Profile has authority to arm/disarm other system areas.

Exception: Disarming of other areas not selected in Display Areas can be accomplished by presenting a card that has disarming authority and matching profile areas with areas assigned in Device Access Areas.

6.10

STRIKE TIME: 5

Strike Time

This option displays if DOOR is selected as Device Type.

Enter a door access time, between 1 and 250 seconds, during which a keypad or access control device relay is activated. Magnetic locks or electric door strikes are connected to the relay and released for the length of the strike time. Default is 5 seconds.

Enter 0 (zero) to activate the device relay with a toggle action. This allows the user to activate or deactivate the device relay each time a valid user code is entered.

The device relay is activated or deactivated until a user code is entered again.

Note: The Request to Exit door access time of a keypad or Model 733 Wiegand Interface Module is not affected by this selection. It remains at 5 seconds.

6.11

STRIKE DELAY: 0

Strike Delay

This option displays if DOOR is selected as Device Type.

Enter the number of minutes, 0 to 9, to delay a door strike after a valid code is entered or a card read occurs. When a valid code or card read or code is received, the activation of the door strike is delayed for the number of minutes programmed. The standard door strike message is sent to the Central Station receiver and logged in the Display Events at the time of card read or code entry and is not delayed. During this delay, all subsequent codes entered or cards presented to the reader for a door strike are ignored and no record of the attempt is stored. Enter 0 (zero) to disable. Default is 0 (zero).

6.12

FIRE EXIT NO YES

Fire Exit Release

Select YES to allow the door access relay at this address to be released whenever Fire panic keys are pressed or a Fire or Fire Verify zone alarm is in the Status List. The relay is reset whenever a Sensor Reset is performed to remove all Fire and Fire Verify zone alarms from the Status List. Select NO to not allow the door access relay at this address to be released.

6.13

OUT GROUP NO YES

Output Group

Select YES to allow the output group (relays) assigned to the user profile to turn ON when the device relay is activated for the programmed strike time. This could be used to operate an elevator control. Default is NO. See the User Profiles section in the Appendix of this document for more information about profiles.

- 6.14**

OVERVERRIDE	NO	YES
-------------	-----------	-----

Schedule Override
 Use this option to allow door ON/OFF schedules to be overridden by the armed condition of the system. Selecting **YES** causes the on time for a door schedule to be ignored when all areas assigned to Access Areas for this device are armed. Should any area become disarmed after the door schedule on time, the device output turns on. A door output which is on during a disarmed period automatically turns off when all access areas assigned to the device become armed, even if the scheduled off time has not been reached. This feature can be used to keep doors locked when a factory opens late, or is forced to close early, due to a snow storm or other cause. Select **NO** to allow door schedules to operate independent of system armed status.
Note: When **OVERVERRIDE** is **YES** and there are no areas programmed in **ACCESS AREAS**, the door schedule for that device does not work. Either set **OVERVERRIDE** to **NO** or enter an area number in **ACCESS AREAS**.
- 6.15**

AUTO FORCE ARM DEVICE?	NO	YES
------------------------	-----------	-----

Auto Force Arm Device?
 Select **YES** to have all Display Areas assigned to this keypad automatically arm and force arm faulted zones at arming. The user is not prompted to select areas to arm or force arm faulted zones after choosing ARM at the keypad. If Closing Code is programmed as **YES**, only the matching areas between the Display Areas and the User Code's authorized areas arm. Also, when **YES** is selected, the user is not prompted to select areas to disarm after entering a code at Entry Delay or after choosing Disarm at the keypad. All matching areas assigned to the User Code and to this keypad are automatically disarmed. When **NO** is selected, the user is prompted to select areas (ALL NO YES) and choose to force arm or bypass at arming and disarming. Default is **NO**.
- 6.16**

DOOR REAL-TIME STATUS?	NO	YES
------------------------	-----------	-----

Door Real-Time Status?
 Select **YES** to have real-time door status messages sent to PC Log reporting and Entré reporting for this device. Messages are sent anytime the panel turns the door relay on or off. Default is **NO**.
- 6.17**

SEND DOOR FORCED MESSAGE?	NO	YES
---------------------------	-----------	-----

Send Door Forced Message?
 Select **YES** to have the panel send a real-time door status message of Forced Open (FO) to PC Log reporting and Entré reporting when the door relay is off, but the door zone has transitioned from its normal state. Default is **NO**.
- 6.18**

PROGRAM 734 OPTIONS?	NO	YES
----------------------	-----------	-----

Program 734/734N Options
 Select **YES** to program a 734 or a 734N/734N-WiFi Wiegand Interface Module. The options displayed for a 734 or a 734N are the same.
 To program a 734, the Device type must be set to DOOR and the Device Communication Type must be set to KPD BUS.
 To program the 734N/734N-WiFi, the Device Type must be set to DOOR and the Device Communication Type must be set to NETWORK.
- 6.18.1**

ACTIVATE ZONE 2 BYPASS?	NO	YES
-------------------------	-----------	-----

Activate Zone 2 Bypass
 Select **YES** to activate the Bypass option.
 Selecting **NO** allows standard zone operation on Zone 2 and displays the ACTIVATE ZONE 3 REX option. Default setting is **NO**.
 If the door being released by the 734/734N/734N-WiFi module is protected (contact installed), you can provide a programmable Bypass entry/exit timer by connecting its contact wiring to a 734/734N/734N-WiFi module Zone 2. When the on-board Form C relay activates and the user opens the door connected to Zone 2, the zone is bypassed for the number of seconds programmed in ZONE 2 BYPASS TIME allowing the user to enter/exit. If Zone 2 does not restore (door closed) within the programmed bypass time, the 734/734N/734N-WiFi piezo pulses during the last ten seconds. If Zone 2 restores prior to the end of the programmed time, the piezo silences. If the zone does not restore before the programmed time, the 734/734N/734N-WiFi ends the bypass and indicates the open or short zone condition to the panel.
- 6.18.2**

ZONE 2 BYPASS TIME:	40
---------------------	-----------

Zone 2 Bypass Time
 Enter the number of Bypass seconds to elapse before the Bypass timer expires. Range is from 20 to 250 seconds. Press any top row select key to enter the number of seconds. If the door remains open when the timer expires a zone open/short is sent to the panel for Zone 2. The default is 40 seconds. .
- 6.18.3**

RELOCK ON ZONE 2 CHANGE?	NO	YES
--------------------------	-----------	-----

Relock on Zone 2 Change?
 Selecting **NO** leaves the relay on when Zone 2 faults to an open or short condition during Bypass. Selecting **YES** turns the 734/734N/734N-WiFi relay off when Zone 2 changes state. The default is **NO**.

6.18.4

ACTIVATE ZONE 3 REX?	NO	YES
-------------------------	-----------	-----

Activate Zone 3 Request to Exit

Selecting YES activates the Zone 3 Request to Exit (REX) option. Selecting NO allows standard zone operation on Zone 3 and displays the ACTIVATE ONBOARD SPEAKER option. Default setting is NO. Optionally connect a PIR (or other motion sensing device) or a mechanical switch to Zone 3 to provide REX capability to the system. When Zone 3 shorts, the on-board Form C relay activates for the programmed number of seconds. During this time, the user can open the protected door to start the programmed Bypass entry/exit timer. After the programmed number of seconds, the relay restores the door to its locked state. The 734/734N/734N-WiFi module provides a bypass-only option for REX on Zone 3. When Zone 3 opens from a normal state, only a Bypass occurs: the on-board relay does not activate. This bypass-only option uses two methods of REX. The first REX device provides the programmed Bypass entry/exit timer. The second REX device, or manual device such as a door knob, unlocks the door. An example of the bypass-only configuration is a door to an office that is locked 24 hours a day. Users pass a REX motion detector positioned by the door to begin the programmed exit timer. Within the programmed number of seconds the user must then manually activate a second device, such as a REX device or manual door knob, to unlock the door. If the door is opened after the programmed number of seconds, the zone goes into alarm.

If you select YES, pressing the COMMAND key displays ZONE 3 REX STRIKE TIME. The Back Arrow returns to the ACTIVATE ZONE 2 Bypass option.

6.18.5

ZN 3 REX STRIKE TIME:	5
--------------------------	----------

Zone 3 REX Strike Time

Enter the number of REX seconds to elapse. Range is from 5 to 250 seconds. Press any top row select key to enter the number of seconds. The default is 5 seconds. Press the COMMAND key to move forward to the ACTIVATE ONBOARD SPEAKER option. The Back Arrow returns to ACTIVATE ZONE 3 REX.

6.18.6

ACTIVATE ONBOARD SPEAKER?	NO	YES
------------------------------	-----------	-----

Activate Onboard Speaker

Select YES to enable the onboard piezo speaker for local annunciation. Select NO to turn the piezo off for all operations. This does not affect remote annunciator open collector (RA) operation. The default is NO.

6.18.7

CARD OPTIONS:	DMP
---------------	------------

Card Options

Press any top row Select key to display options. Press the select key under DMP, CUSTOM, or ANY to select that option. Select DMP to indicate the reader sends a 26-bit DMP data string. Press the COMMAND key to display REQUIRE SITE CODE.

Note: When set to DMP, the 734/734N/734N-WiFi converts 17 bits of the 26-bit data string into a 5-digit number.

Select CUSTOM if using a non-DMP card or user code length of 6 to 10 digits. Default is DMP.

Select ANY to allow all card reads to activate the door strike relay. The door strike relay is activated for the length of time programmed in ZN 3 REX STRIKE TIME. No user code information is sent to the panel.

CARD OPTIONS: DMP CUSTOM ANY
--

6.18.8

WIEGAND CODE LENGTH:	26
-------------------------	-----------

Custom Card Definitions

Weigand Code Length

When using a custom credential, enter the total number of bits to be received in Wiegand code including parity bits.

Press any top row Select key to enter a number between 1-255 to equal the number of bits. Default is 26 bits.

Typically, an access card contains data bits for a site code, a user code, and start/stop/parity bits. The starting position location and code length must be determined and programmed into the 734/734N/734N-WiFi Module.

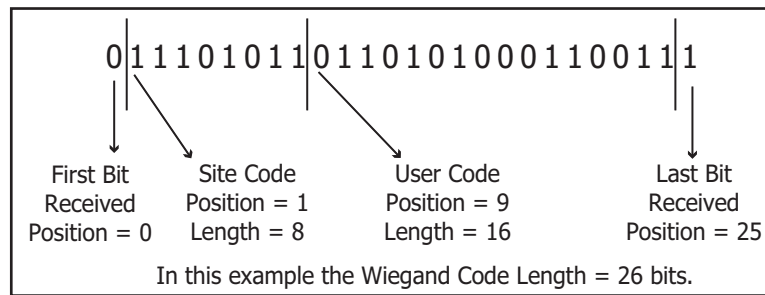

- 6.18.9** SITE CODE POSITION: 1 **734 Site Code Programming**
Site Code Position
 Enter the site code start position in the data string. Press any top row Select key to enter a number between 0-255. Default is 1.
- 6.18.10** SITE CODE LENGTH: 8 **Site Code Length**
 Enter the number of characters the site code contains. Press any top row Select key to enter a number between 1-16. Default is 8.
- 6.18.1** USER CODE POSITION: 9 **User Code Position**
 Define the User Code start bit position. Press any top row Select key to enter a number between 0-255. Default is 9.
- 6.18.12** USER CODE LENGTH: 16 **User Code Length**
 Define the number of User Code bits. Press any top row Select key to enter a custom number. Custom numbers can only be a number between 16-32. On a 734N/734N-WiFi Module, custom numbers can be between 1-255. The default is 16.
- 6.18.13** REQUIRE SITE CODE? NO YES **Require Site Code**
 Press the top row Select key under YES to use a site code.
 In addition to User Code verification, door access is only granted when any one site code programmed at the SITE CODE ENTRY option matches the site code received in the Wiegand string.
- 6.18.13.1** SITE CODE 1: - **Site Code Display**
734 Module: You can program up to 8 three-digit site codes. Site code range is 0-999. Any previously programmed site codes display. Dashes represent blank site codes. Default is blank.
Note: A card with a site code greater than three digits cannot be used. Use only cards with three-digit site codes.
SITE CODE 1: (1-65,535) 127 **734N/734N-WiFi Module:** You can program up to 8 five-digit site codes. Site code range is 1-65535. Any previously programmed site codes display. Site Code 1 defaults to 127. Site Codes 2-8 default to blank. Dashes represent blank site codes.
 Site Code 1 displays first. Enter a site code number followed by the Command key to advance to the next prompt, Site Code 2. To delete an existing site code, press any Select key. Either enter a new site code followed by Command, or press Command to leave blank and continue to the next site code. Repeat these steps to change, delete, or add up to 8 site codes.
- 6.18.14** NO OF USER CODE DIGITS: 5 **Number of User Code Digits**
 The 734 module recognizes user codes from four to ten digits in length. The 734N/734N-WiFi module recognizes user codes from 1-10 digits in length. Press any top row Select key to enter a user code digit length between 4-10 digits. This number must match the user code number length being used by the panel. Default is 5. For an XR100 Area System, use 4 to 10 digits (typically 5).
 Any selection above 5 digits require entry of the custom card definitions with custom site and user code positions for the Wiegand string. When searching the bit string for the user code, the digits are identified and read from left to right.

REMOTE OPTIONS

6.18.15

No Communication with Panel

This option defines the relay action when communication with the panel has not occurred for five seconds. Press any top row Select key to display relay action options. Press the Back Arrow key to return to the NO OF USER CODE DIGITS:.

Choose the action required:

Press the first Select key to choose OFF [Default] (Relay Always Off) – The relay does not turn on when any Wiegand string is received. Off does not affect any REX operation.

Press the second Select key to choose SITE (Accept Site Code) – Door access is granted when the Wiegand site code string received matches any site code programmed at SITE CODE ENTRY. For details refer back to the REQUIRE SITE CODE option.

Press the third Select key to choose ANY (Any Wiegand Read) – Door access is granted when any Wiegand string is received.

Press the fourth Select key to choose ON (Relay Always On) – The relay is always on. Press the COMMAND key to display the next action.

Press the first Select key to choose LAST (Keep Last State) – The relay remains in the same state and does not change when communication is lost.

After choosing the action, the NO COMM WITH PNL option and the newly defined action display.

Programming is now complete. Press the COMMAND key to display DEVICE NO.

Remote Options

7.1

Remote Options

This section allows you to enter the information needed for Remote Command/Remote Programming operation.

7.2

Remote Key

This option allows you to enter a code of up to 16 digits for use in verifying the authority of an alarm or service receiver to perform a remote command/programming session. The Remote Link™ program must give the correct key to the panel before being allowed any remote functions. All panels are shipped from the factory with the key preset as blank.

To enter a remote key or change the current one, press a top row Select key and enter any combination of up to 16 digits. Press COMMAND. The current key display as astericks.

7.3

Remote Disarm

YES allows the panel to be disarmed remotely. NO disables remote disarming. Default is NO.

7.4

Armed Answer Rings

Enter the number of rings the panel counts before answering the phone line when all system areas are armed. Any number from 0 to 15 can be entered. If 0 (zero) is entered, the panel does not answer the phone when all system areas are armed.

The default Armed Rings is 8 (eight).

Answering machine bypass procedure: Entering a number greater than 0 (zero) into either Armed Rings or Disarmed Rings, allows a central station operator to connect remotely with the panel.

How it works: The operator calls the panel, allows the telephone to ring one time, and then hangs up. The panel stores this as an attempt to communicate. The operator then calls back within 30 seconds. The panel seizes the telephone line to allow remote programming.

Note: This feature does not interfere with the normal operation of the Arm Rings or Disarm Rings functions.

7.5

Disarmed Answer Rings

Enter the number of rings the panel counts before answering the phone line while any system areas are disarmed. Any number from 0 to 15 can be entered. If 0 (zero) is entered, the panel does not answer the phone when any system area is disarmed. The default number of Disarmed Rings is 8 (eight).

- 7.6** PC MODEM NO YES **PC Modem**
 YES allows the panel to answer the telco link and connect with Remote Link through the PC Modem at 2400 baud. NO disables PC Modem communication.
- 7.7** ALR RCVR NO YES **Alarm Receiver Authorization**
 Select YES to enable remote commands and programming to be accepted from the alarm SCS-1R Receiver. The Remote Key option can also be required.
 With YES selected, the panel requests the receiver key during its first communication with the first SCS-1R Receiver. The panel retains this alarm receiver key in memory and allows remote commands to be accepted from the alarm receiver. If an alarm occurs during a remote connect, the alarm report is immediately sent to this receiver only.
 When NO is selected, remote commands and programming are not accepted from the alarm SCS-1R Receiver.
- 7.8** SVC RCVR NO YES **Service Receiver Authorization**
 YES enables remote commands and programming to be accepted from a secondary service receiver other than the alarm SCS-1R Receiver. The Remote Key option can also be required.
 With YES selected, the panel requests the service receiver key the first time it is contacted by the service receiver. The panel retains this service receiver key in memory and accepts remote commands from the service receiver.
 If an alarm occurs during a remote connect, the panel disconnects from the service receiver and calls the alarm receiver. Alarm reports are only sent to the alarm receiver. It is important that the alarm receiver key and the service receiver key programmed at the central station are NOT the same so the panel can determine the difference between receivers.
 When NO is selected remote commands and programming are not accepted from a secondary service receiver.
 This option must be YES to allow programming from a directly connected computer or an iCOM/iCOM-E.
- 7.9** MANUFACTURER **Manufacturer Authorization**
 AUTH? NO YES Select YES to allow DMP Technical Support technicians to access the panel during system service or troubleshooting. This authorization automatically expires within one hour.
 DMP remote service is provided on a read only basis: DMP technicians can look at the system programming and make suggestions only. Alterations can only be accomplished by installing company service personnel.
- 7.10** ALLOW NETWORK **Allow Network Remote**
 REMOTE? NO YES This option displays only if the panel has network capability. YES allows remote programming over the network. Changing this prompt does not change any other network programming prompts. Default is YES.
- 7.10.1** NETWORK PROG **Network Programming Port**
 PORT: **2001** Enter the programming port number. The programming port identifies the port used to communicate messages from the panel. The default Programming Port setting is 2001.
- 7.10.2** ENCRYPT NETWORK **Encrypt Network Remote**
 REMOTE? NO YES YES encrypts data sent over network. Default is NO.
- 7.11** ALLOW CELL **Allow Cellular Remote**
 REMOTE? NO YES YES allows remote programming using cellular connection. Default is YES.
- 7.11.1** FIRST GPRS APN: **First GPRS APN**
 NMRX.CA.APN Enter the first APN (Access Point Name). This allows an access point for cellular communication and is used to connect to a DNS network. The APN may contain two lines of 16 characters to equal 32 characters. Default is set to NMRX.CA.APN.
 -
- SECOND GPRS APN: **Second GPRS APN**
 INTERNET.COM Enter the second APN (Access Point Name). This works as a backup in case the first APN fails. The APN may contain two lines of 16 characters to equal 32 character
 - Default is set to INTERNET.COM.

REMOTE OPTIONS

- 7.11.2**

ENCRYPT CELL REMOTE?	NO YES
-------------------------	---------------

Encrypt Cellular Remote
YES encrypts data sent over a cellular connection. Default is NO.
- 7.12**

ENTRE CONNECTION:	NONE
----------------------	-------------

Entré Connection
This option displays only if the panel has network capability. Select NET to allow a dedicated network connection with Entré. Options are NONE or NET. Default is NONE.
- 7.12.1**

ENTRE INCOMING TCP PORT:	2011
-----------------------------	-------------

Entré Incoming TCP Port
This option displays only if NET is chosen for the Entré connection. Enter the programming port number for the incoming Entré connection. The programming port identifies the port used to communicate messages to and from the Entré software. This port cannot be the same port as programmed in Network Programming Port. The default Programming Port setting is 2011.
- 7.12.2**

ENTRE IP	
000.000.000.000	

Entré IP Address
This option displays only if NET is chosen for the Entré connection. Enter the Entré IP address where the panel sends network messages. The Entré IP Address must be unique and cannot be duplicated on the network. Enter all 12 digits and leave out the periods. For example, enter IP address 192.168.0.250 as 192168000250. The periods display automatically. Default is 0.0.0.0.
- 7.12.3**

ENTRE OUTBOUND TCP PORT:	2001
-----------------------------	-------------

Entré Outbound TCP Port
This option displays only if NET is chosen for the Entré connection. Enter the programming port number for the outbound Entré connection. The programming port identifies the port used to communicate messages to the Entré software. Default is 2001.
- 7.12.4**

ENTRE BACKUP IP:	
000.000.000.000	

Entré Backup IP Address
This option displays only if NET is chosen for the Entré connection. Enter the IP backup address where the panel sends network messages if the first Entré IP Address fails. The Entré IP Address must be unique and cannot be duplicated on the network. Enter all 12 digits and leave out the periods. For example, enter IP address 192.168.0.250 as 192168000250. The periods display automatically. Default is 0.0.0.0
- 7.12.5**

ENTRE BACKUP TCP PORT:	2001
---------------------------	-------------

Entré Backup TCP Port
This option displays only if NET is chosen for the Entré connection. Enter the backup programming port number for the outbound Entré connection in case the connection to the primary IP fails. Default is 2001.
- 7.12.6**

ENTRE CHECKIN MINUTES:	0
---------------------------	----------

Entré Checkin
Select the rate at which check-in messages are sent over the Entré connection. Select 0 (zero) to disable check in messages. Range is 0, 3-240 minutes. Default is 0.
- 7.12.7**

ENTRE PASSPHRASE	
-	

Entré Passphrase
To enable encryption enter an 8 to 16-character Passphrase using alphanumeric characters. If you leave the Passphrase blank, the panel communicates with Entré, but the data is not encrypted. The Passphrase is blank by default.
- 7.13**

SEND LOCAL CHANGES?	NO
------------------------	-----------

Send Local Changes
This option allows the panel to automatically update a remote programming computer at the central station with any changes made to the panel.
- | | |
|-------------------------|--|
| SEND LOCAL
NO NET DD | |
|-------------------------|--|

 Select NET or DD to send local programming changes or User Menu changes to user codes, user profiles, schedules, or holiday dates to Remote Link after exiting the programming or User Menu. If NET is selected, changes are sent using Network. If DD is selected, changes are sent using Dialer. Default is NO to disable this feature.
- 7.13.1**

REMOTE CHANGE IP	
000.000.000.000	

Remote Change IP
This option displays when NET is selected for Send Local Changes. Enter the IP address containing up to 12 digits. The Net IP Address must be unique and cannot be duplicated on the network. Enter all 12 digits and leave out the periods. For example, enter IP address 192.168.0.250 as 192168000250. The periods display automatically. Default is 000.000.000.000

7.13.2 **Remote Change Port**
 This option displays when NET is selected for Send Local Changes. Enter the Port number. Valid numbers are from 0 to 65535. Default is 2002.

7.13.3 **Remote Telephone Number**

 This option displays when DD is selected for Send Local Changes. Press COMMAND to enter the phone number the panel dials when sending programming changes. After entering a phone number, the panel sends any panel changes to Remote Link. The phone number can have two lines of 16 characters each to equal 32. Enter a P to program a two second pause in the dialing sequence. The P character counts as part of the 32 allowable characters. Enter *70P as the string first characters to cancel call waiting. Dial tone detect is an automatic panel function.

System Reports

8.1 **System Reports**
 Select specific system reports the panel sends to the receiver.

8.2 **Abort Report**
YES allows the panel to send an alarm abort report to the receiver any time an area is disarmed during Transmit Delay before an alarm report is sent and the Bell Cutoff Time has not expired. After disarming an area, if any other area remains armed and has zone(s) in alarm, the alarm abort report is not sent.
 If the communication type is set to DD, a Warning: Alarm Bell Silenced report is also sent if the alarm bell is silenced.
Note: Abort Reports are not sent for Fire, Fire Verify, or Supervisory type zones.

8.3 **Restoral Reports**
 This option allows you to control when and if a zone restoral report is sent to the central station receiver. Press any Select key to display the following options:
 NO - Disables the zone restoral report option. Zones continue to operate normally but do not send restoral reports to the receiver.
YES - Enables the zone restoral report option. Zone restorals are sent whenever a zone restores from a trouble or alarm condition.
DISARM - Causes the panel to send restoral reports for a non-24-hour zone whenever a zone that has restored from a trouble or alarm condition is disarmed. All 24-hour zones send restoral reports as they restore.
YES allows the panel to send all zone bypasses, resets, and force arm reports to the receiver. The bypass report includes the zone number, zone name, and the user name and number of the individual operating the system. Reports are only sent if O/C User in Communications is set YES for Receiver 1 or Receiver 2.

8.5 **Schedule Change Reports**
YES allows the panel to send all schedule changes to the receiver. The report includes the day, opening time, closing time, extend schedule time, and the user name and number of the individual making the change. Schedule changes made through Remote Link™ are not sent to the printer or Display Events.

8.6 **Code Change Reports**
YES allows the panel to send all code additions, changes, and deletions to the receiver. The code change report includes the user name and number added or deleted and the user name and number of the individual making the change. Code changes made through Remote Link™ are not sent to the printer or Display Events. Reports are only sent if O/C User in Communications is set YES for Receiver 1 or Receiver 2. The default setting is YES.

SYSTEM OPTIONS

8.7 **Access Keypads**
Select the keypad addresses (1 through 8) that send door access reports to the receiver. Enter the keypad number using the digit keys. An asterisk next to the number indicates that the keypad is selected.
A report is sent with each door access made from the selected keypads. Keypads at addresses not selected still operate the door relay but do not send access reports. The report includes the user number, user name, keypad address, and device name.

8.8 **Ambush**
YES allows an ambush report to be sent anytime user code number 1 is entered at a keypad. NO disables the ambush report and allows user number 1 to operate the same as all other codes.

System Options

9.1 **System Options**
This section allows you to select system-wide parameters.

9.2 **System**
This option allows you to program how the areas operate for arming and disarming. The options you can choose are listed below:

 AREA - All eight areas can be programmed and operated independently.
ALL/PERIMETER - Area 1 is the Perimeter and Area 2 is the Interior.

HOME/SLEEP/AWAY - Area 1 is the Perimeter, Area 2 is the Interior, and Area 3 is the Bedrooms. With the HOME/SLEEP/AWAY option, the user can:

1. Select HOME to arm just the perimeter.
2. Select SLEEP to arm the perimeter and interior (non bedroom areas).
3. Select AWAY to arm all three areas.

Note: A Home/Sleep/Away system can be configured to use all three areas or only use the Home and Away areas.

HOME/SLEEP/AWAY WITH GUEST- This allows the alarm system to be divided into a main house HOME/SLEEP/AWAY system and a guest house that is also set up as a HOME/SLEEP/AWAY system.

Areas 1,2, and 3 are the Perimeter, Interior, and Bedrooms for the Main house system. Areas 4, 5, and 6 are the Perimeter, Interior, and Bedrooms for the Guest system. These areas are automatically assigned per system and cannot be changed. See Display Areas in Device Setup to assign keypads to a system. Zones are assigned to a system by assigning the system's area numbers to the zone in Zone Information programming.

When either All/Perimeter or Home/Sleep/Away is selected, the area names are automatically assigned and cannot be modified.

Note: Areas 3-6 in an All/Perimeter system and areas 4-6 in a Home/Sleep/Away system are not available for use and are initialized.

9.3 **Instant Arming**
When YES is selected, the arming keypad displays INSTANT for selection during the exit countdown delay when arming fewer than all areas of the system. At the time instant arming is selected, any entry and exit delays programmed for the areas being armed are ignored. The entry delay for previously armed areas is not affected by instant arming. When NO is selected, INSTANT does not display during arming. Default is NO for an Area System, and YES for an All/Perimeter or Home/Sleep/Away system.

9.4 **Closing Wait**
When YES is selected, the keypad displays ONE MOMENT... while waiting for an acknowledgement from the receiver before arming the selected area(s) and performing a Bell Test (if selected). Exit delays begin after the Closing Wait. Opening/Closing reports must be YES to enable Closing Wait.

- 9.5**

ENTRY DLY 1:	30
ENTRY DLY 2:	60
ENTRY DLY 3:	90
ENTRY DLY 4:	120

Entry Delay 1
Enter the Entry Delay time for all Exit type zones programmed to use Entry Delay 1. When an armed Exit type zone is faulted, the keypad prewarn tone begins sounding. All keypads programmed to prewarn for that zone display ENTER CODE:- and the name of the zone causing the entry delay. When the first digit of a code is entered, the prewarn tone stops at that keypad. If an invalid code is entered, the prewarn tone begins sounding again. The area must be disarmed before the delay expires or an alarm report is sent to the receiver and an alarm sounds. All zones in that area are delayed along with the Exit zone. Entry Delay times can be from 30 to 250 seconds. Repeat the above for each entry delay being used in the system.
Note: Specific Exit Error operation is based on the Entry Delay used (1-4) with an EX type zone. See Exit Delay.
- 9.6**

CRS ZONE TM:	4
--------------	---

Cross Zone Time
Enter the time allowed between zone faults. When zones are cross zoned, the same zone or a second cross zoned zone must fault within this time in order for an alarm report for both zones to be sent to the receiver. If the cross zone time expires without the second zone faulting, only a zone fault from the first zone is reported. Cross-zone time can be from 4 to 250 seconds. Entering 0 (zero) disables this function. Default is 4. See the Appendix.
- 9.7**

RETARD DELAY:	10
---------------	----

Zone Retard Delay
Enter the retard time assigned to Fire, Supervisory, Auxiliary 1, Auxiliary 2, Arming, and Panic type zones. The retard delay only functions when the zone is shorted. The zone must remain shorted for the entire length of the Retard Delay before being recognized by the panel. The Zone Retard Delay can be from 1 to 250 seconds. Entering a 0 (zero) disables this function.
- 9.8**

PWR FAIL HRS:	1
---------------	---

Power Fail Delay
This option tracks the duration of an AC power failure. When the AC power is off for the length of the programmed delay time, an AC power failure report is sent to the receiver. The delay time can be from 1 to 15 hours. Entering a 0 (zero) sends the power failure report after a 15-second delay. The default setting is 1.
- 9.9**

SWGRBYP TRIPS:	2
----------------	---

Swinger Bypass Trips
Enter the number of times (1-6) a zone can go into an alarm or trouble condition within one hour before being automatically bypassed. You can select one or two trips. Bypassed zones are automatically reset when the area they are assigned to is disarmed. All 24-hour zones are reset when any area of the system is disarmed. A programming Stop operation restores a bypassed zone. Entering 0 (zero) disables this function. Default is 2.
How it works
The panel hour timer starts at 59 minutes past the hour. If the hour timer expires before the trip counter is exceeded, the trip counter returns to 0 (zero). If the trip counter is exceeded before the hour expires, the zone is automatically bypassed by the panel. A Bypass Report is sent to the receiver if Bypass Reports is YES.
- 9.10**

RST SBYP	NO	YES
----------	----	-----

Reset Swinger Bypass
When YES is selected, an automatically bypassed zone is reset if it remains in a normal condition for one complete hour after being bypassed. A report of the automatic reset is sent to the receiver if Bypass Reports has been selected as YES. Default is NO.
- 9.11**

TIME CHG	NO	YES
----------	----	-----

Time Zone Changes
This function allows the panel to request automatic time changes from the DMP SCS-1R Receiver on Path 1. For the receiver to send time changes, it must be programmed to send time changes and must be receiving time change updates from the network automation computer at least every 24 hours. Default is YES.

HRS FROM GMT:	6
---------------	---

 When time zone is programmed YES, enter the number (0-23) that indicates the Greenwich Time zone (GMT) where the panel is located. The default is 6.

SYSTEM OPTIONS

GMT	City/Time Zone
0	London, Monrovia, Lisbon, Dublin, Casablanca, Edinburgh
1	Cape Verde Island, Azores
2	Mid-Atlantic, Fernando de Noronha
3	Buenos Aires, Georgetown, Brasilia, Rio de Janeiro
4	Atlantic Time (Canada), Caracas, La Paz, Santiago
5	Eastern Time (US, Canada) Bogota, Lima, Arequipa
6	Central Time (US, Canada), Mexico City, Saskatchewan
7	Mountain Time (US, Canada), Edmonton
8	Pacific Time (US, Canada), Tijuana
9	Alaska
10	Hawaii
11	Midway Island, Samoa
12	Fiji, Marshall Island, Wellington, Auckland, Kwajalein, Kamchatka

GMT	City/Time Zone
13	New Cadelonia
14	Guam, Sydney
15	Tokyo, Seoul
16	Hong Kong, Singapore
17	Bangkok, Hanoi
18	Dhaka, Almaty
19	Islamabad, Karachi
20	Abu Dhabi, Kazan
21	Moscow, Bagdad
22	Eastern Europe
23	Rome, Paris, Berlin

9.12 LATCH SV NO YES Latch Supervisory Zones

Selecting YES latches supervisory zone alarms on the keypad display until the sensor reset operation is performed. Selecting NO automatically clears the alarm from the keypad display when the supervisory zone restores to a normal condition. Default is YES.

9.13 PROG LANGUAGE Programming Menu Language

Press the COMMAND key to select the programming language. Any changes in PROG LANGUAGE do not take effect until the STOP routine completes.

PRI LANG: ENGLISH The current primary programming language displays. The default language is English. Press a Select key to change the primary programming language.

ENG SPN FRN Select the primary programming language.
 ENG = English (ENGLISH)
 SPN = Spanish (ESPAÑOL)
 FRN = French (FRANCAIS)

SEC LANG: NONE The current secondary programming language displays. Selecting a secondary language allows the installer to view programming in English, Spanish, or French. When the Programming Menu is accessed, the installer is prompted to choose the programming display language. If SEC LANG: is set to NONE, the option to choose a language does not display. To select a secondary language, press the Select key below the language. Default is NONE.

NONE ENG SPN FRN Select the secondary programming language.
 NONE = No secondary language options are displayed
 ENG = English (ENGLISH)
 SPN = Spanish (ESPAÑOL)
 FRN = French (FRANCAIS)

9.14 USER LANGUAGE User Menu and Status List Language

Press the COMMAND key to select User language.

PRI LANG: ENGLISH The current primary user language displays. The default language is English. Press a Select key to change the primary User language.

ENG SPN FRN Select the primary user language.
 ENG = English (ENGLISH)
 SPN = Spanish (ESPAÑOL)
 FRN = French (FRANCAIS)

SEC LANG: NONE The current secondary user language displays. Selecting a secondary user language allows the user to view the User Menu and Status List text in English, Spanish, or French. When the User Menu is accessed, the user is prompted to choose the display language. Status List text displays in the selected language until another language is chosen. If SEC LANG: is set to NONE, the option to choose a language does not display. To select a secondary language, press the Select key below the language. Default is NONE.

For example, when Spanish is selected at a keypad, the User Menu and Status List text display in Spanish at **that** keypad. When the user later accesses the keypad, pressing the COMMAND key once displays the option for English, Spanish, or French. Pressing the COMMAND key again continues to display the Status List text in Spanish. Later on, if English or French is selected at **that** keypad, the User Menu and Status List text display in the selected language at **that** keypad.

NONE ENG SPN FRN Select the secondary user language.
 NONE = No secondary language options are displayed
 ENG = English (ENGLISH)
 SPN = Spanish (ESPANOL)
 FRN = French (FRANCAIS)

9.15 **BYPASS LIMIT 0 Bypass Limit**

Enter the maximum number of zones (0 to 8) that can be bypassed in any single area when that area is being armed at a keypad. If more zones than the limit are in a non-normal state or already bypassed at arming, arming does not occur and Arming Stopped displays. The Bypass limit does not affect auto arming, keyswitch arming, or remote arming. Entering 0 (zero) allows no limit. Default is 0 (zero).

9.16 **HOUSE CODE**

WIRELESS HOUSE CODE: 0

When using a DMP wireless system, enter a house code between 1 and 50. When using FA Series wireless enter 99. See Wireless programming in Zone Information. Default is 0 indicating no wireless system is being used.

The DMP house code identifies the panel, DMP receiver, and DMP transmitters to each other. When operating, the DMP receiver listens for transmissions that have the programmed house code and transmitter serial number.

Note: The flexibility of DMP two-way wireless operation allows an existing house code to be changed in the panel at any time. The transmitters may take up to two minutes to learn the new house code and continue operation.

Note: When any wireless zone programming is changed in the panel, wireless receiver zone programming is updated. At that point, all wireless zones display as normal for approximately 1 minute, regardless of the actual state of the zone.

9.17 **DETECT WIRELESS JAMMING: NO YES Detect Wireless Jamming**

DETECT WIRELESS JAMMING: NO YES

This option displays when the House Code entered is for a DMP 1100 Series Wireless system (1-50). When enabled and the wireless receiver detects jamming, a trouble or alarm message displays in the Status List and is sent to the central station receiver. Select YES to enable jamming messages to display in the Status List. Select NO to disable jamming messages. Default is NO.

9.18 **WIRELESS AUDIBLE ANNUNCIATION**

WLS AUDIBLE: DAY

WIRELESS AUDIBLE ANY DAY MIN

This option displays when the House Code entered is for a DMP 1100 Series Wireless system (1-50). Press any top row key to select the keypad buzzer annunciation method for wireless low battery and missing messages. Select ANY to enable annunciation anytime. Select DAY to enable annunciation except during sleeping hours (9 PM to 9 AM). Select MIN (minimum) to annunciate only Fire and Fire Verify zones during daytime hours (9 AM to 9 PM). Default is DAY.

SYSTEM OPTIONS

9.19

KEYPAD PANIC KEYS
ENABLED: NO YES

Enable Keypad Panic Keys

This option allows the two-button panic key operation selected at the keypad to send the Panic, Emergency, or Fire message to the central station receiver. Select YES to enable the two-button panic operation to operate. To disable the two-button panic operation, select NO. Default is YES.

9.20

OCCUPIED
PREMISE: NO YES

Occupied Premise

For All/Perimeter or Home/Sleep/Away systems, select YES to allow the panel to automatically disarm the interior area(s) when arming all areas and a perimeter zone is not tripped during the exit delay. Select NO to disable this feature. Default is YES.

Note: With a Home/Sleep/Away with Guest arming system, this feature only applies to the main system.

9.21

ENHANCED ZONE
TEST: NO YES

Enhanced Zone Test

Select YES to allow enhanced zone test operation. The default is NO. Enhanced operation allows:

- Panic Test and Walk Test functions can be restricted to operate only during an Area 32, Shift 4 schedule if programmed. If no schedule is entered, the walk test always operates.
- A Verify message is sent each time a zone is tested. If a zone is tripped multiple times, a Verify message is sent for each trip. This allows the Central Station to record the number of devices per zone.
- The Verify message for each zone test is sent at the time the trip occurs instead of at the end of Walk Test.
- The System Test Begin and System Test End Central Station messages indicate the type of zone being tested. The System Test Begin message also includes the user name and number.

9.22

DUAL EOL NO YES

Dual EOL

Select YES to enable the use of dual 1K EOL resistors on panel zones one to eight. This zone operation is used for medium or high risk ULC Listed applications. Select NO to disable this feature. Default is YES.

Note: If using a 714, 714-8, or 714-16 for dual zone protection, program two zones as the same name or equivalent and connect to the contact in the protected area. Refer to the Dual Zone Protection diagram in the XR100 Series Canadian Installation Guide for complete details.

9.23

SEND 16 CHAR
NAMES: NO YES

Send 16 Character Names

This option allows central stations to select being sent either the first 16 characters of the name field or the entire programmed name, up to 32 characters, for user name, user profile, zone name, area name, output name, and group name. Select YES to have the first 16 characters of the name field sent to the central station. Select NO to send the exact number of characters entered in the name field from 1 up to the maximum of 32 characters. Default is YES.

Note: Using 32 character names increases the length of the DMP Serial 3 message from the panel to the receiver. The SCS-1R receiver does not require an update to pass these messages to the Host Automation System of the Central Station. Before using names longer than 16 characters, determine whether the Host Automation System of your Central Station can accept 17 to 32 character names. If not, only use 16 character names.

9.24

KEYPAD ARMED LED
ALL

Keypad Armed LED

This option displays only when using an Area system. Press any top row key to select the operation of the Armed LED on the keypad. Select ALL to require all keypad display areas to be armed before the keypad Armed LED turns on. Select ANY to turn on the keypad Armed LED when any keypad display area is armed. Default is ALL.

KEYPAD ARMED LED
ALL ANY

9.25

USE FALSE ALARM
QUESTION NO YES

Use False Alarm Question

Select YES to display IS THIS A FALSE ALARM? NO YES at the keypad in place of CANCEL VERIFY when a burglar alarm occurs. This operates for ALL/PERIM and HOME/SLEEP/AWAY arming systems. Default is NO.

Bell Options

10.1

BELL OPTIONS

Bell Options

This section allows you to program the panel bell output functions.

10.2

BELL CUTOFF: 15

Bell Cutoff Time

Enter the maximum time from 1 to 99 minutes the Bell Output remains on. If the area is disarmed, the cutoff time resets. Enter 0 (zero) to provide continuous bell output. The default is 15 minutes.

Note: For SIA CP-01 False Alarm Reduction Installations, the Bell Cutoff Time must be set to a minimum of six (6) minutes.

10.3

BELL TST NO YES

Automatic Bell Test

Select YES to turn on the Bell Output for 2 seconds each time the system is completely armed from a keypad. This test is delayed until the Closing Wait acknowledge is received (if programmed). If the Closing Wait acknowledge is not received within 90 seconds, the bell test does not occur. Arming performed from an Arming zone or from Remote Link™ does not activate the Bell Test.

10.4

BELL OUTPUT: 0

Bell Output

Enter the output number when needed to follow the panel Bell Output operation for all action and off conditions. Enter 0 (zero) to disable.

Note: When BELL ACTION is set to T for Temporal Code 3, the Bell Output action for an LX-Bus output is pulse.

Note: Bell Output should not be programmed for a Model 1135 Wireless Siren when programmed in Output Information to Trip with Panel Bell.

10.5

BELL ACTION

Bell Action

This section defines the type of Bell Output for zone alarms. Press COMMAND to display the default Bell Output for each zone type. Press any Select key and enter S for a Steady Bell Output, P for a Pulsed output, T for a Temporal Code 3 output, and N for no Bell Output.

Note: Trouble conditions do not activate the Bell Output.

10.5.1

FIRE TYPE: P

Fire Bell Action

Defines Bell Action for Fire Type zones. The default is P.

10.5.2

BURGLARY TYPE: S

Burglary Bell Action

Defines Bell Action for Burglary Type zones and Exit Error output. The default is set at S.

10.5.3

SUPRVSRY TYPE: N

Supervisory Bell Action

Defines Bell Action for Supervisory Type zones. The default is set at N.

10.5.4

PANIC TYPE: N

Panic Bell Action

Defines Bell Action for Panic Type zones. The default is set at N.

10.5.5

EMERGENCY TYPE: N

Emergency Bell Action

Defines Bell Action for Emergency Type zones. The default is set at N.

10.5.6

AUXLRY 1 TYPE: N

Auxiliary 1 Bell Action

Defines Bell Action for Auxiliary 1 Type zones. The default is set at N.

10.5.7

AUXLRY 2 TYPE: N

Auxiliary 2 Bell Action

Defines Bell Action for Auxiliary 2 Type zones. The default is set at N.

Output Options

11.1

OUTPUT OPTIONS

Output Options

This section allows you to program panel output options. The panel provides two Form C relays (1 and 2) and four switched ground (open collector) outputs numbered 3 to 6. Use the J22 LX-Bus on the panel and multiple 716 Output Expander Modules to support up to 100 additional relay outputs. Alternately, when using the 1100X wireless receiver, 45 wireless outputs are available. Refer to the XR100 Series Canadian Installation Guide (LT-0899CAN) for complete information.

Select from the following output numbers:

- 1 to 6
- 450 to 474 – Slow response time* wireless outputs (activates within 15 seconds)
- 480 to 499 – Fast response time* wireless outputs (activates within 1 second)
- 500 to 599 – LX-Bus output
- D1 to D8 – Keypad door strike relay for addresses 1-8
- G1 to G20 – Output group

* The response time of a wireless output is the time it takes for a wireless output to activate once the panel event occurs. You determine whether a wireless output is a slow or fast response based on the output number assigned. A slow response output number extends battery life, but response time may be up to 15 seconds. A fast response output number responds within 1 second, but reduces battery life. Refer to the specific wireless output installation guide to determine battery life.

11.2.1

CO OUTS: - - - - -

Cutoff Output

Outputs 1 to 6 can be entered here to turn off after a time specified in CUTOFF TIME. To disable this option, press any Select key to clear the display then press COMMAND. The Cutoff Output displays dashes when no outputs are selected.

11.2.2

CUTOFF TIME: 0

Output Cutoff Time

If a Cutoff Output (1-6) is assigned, enter a Cutoff Time of 1 to 99 minutes for the output to remain on. Enter 0 (zero) for continuous output.

11.3

COMM TRBL OUT: 0

Communication Trouble Output

Enter the output number to turn on when a DD system fails to communicate on three successive dial attempts or if the backup communication line transmits a report. The Communication Trouble Output also turns on when NET is selected as the primary communication method and NET communication fails after one minute. When NET communication is restored the Communication Trouble Output automatically turns off.

To manually turn the output off, disarm any area or select Off for the output number in the User Menu Outputs On/Off section. Enter 0 (zero) to disable this output.

11.4

FIRE ALR OUT: 0

Fire Alarm Output

Enter the output number to turn on when a fire type zone is placed in alarm. The output is turned off using the Sensor Reset option while no additional fire type zones are in alarm. Enter 0 (zero) to disable. This output is not compatible with Cutoff Outputs.

11.5

FIRE TRB OUT: 0

Fire Trouble Output

Enter the output number to turn on when a fire type zone is placed in trouble, when a supervisory type zone is placed in trouble, or when any system monitor (AC, Battery, Phone Line 1 or Phone Line 2) is placed in trouble. The output turns off when all fire and supervisory type zones, or system monitors are restored to normal. Enter 0 (zero) to disable this output. This output is not compatible with Cutoff Outputs. This output can be connected to a lamp, LED, or buzzer using the DMP Model 716 Output Expansion Module.

- 11.6** PANIC ALM OUT: 0 **Panic Alarm Output**
 Enter the output number to turn on when any Panic type zone is placed in an alarm condition. The output is turned off after all Panic zones are restored from an alarm condition and a Sensor Reset is performed. Enter 0 (zero) to disable.
- Wireless Outputs**
- The Panic Alarm is compatible with the Model 1118 Wireless Remote Indicator Light and the Model 1116 Wireless Relay Output connected to a Model 572 Indicator LED.
 - When a Panic Alarm occurs, the LED turns on steady for five minutes and then turns off.
 - When a Panic Test is initiated from the keypad, the LED flashes quickly for five minutes.
 - For a Panic Alarm, a fast response wireless output number is recommended.
- 11.7** AMBUSH OUT: 0 **Ambush Output**
 Enter the output number to turn on when an Ambush code is entered at a keypad. The output is turned off using the Sensor Reset option. Enter 0 (zero) to disable.
- 11.8** ENTRY OUT: 0 **Entry Output**
 Enter the output number to turn on at the start of the entry delay time. The output turns off when the area is disarmed or the entry delay time expires. Enter 0 (zero) to disable.
- 11.9** EXIT OUT: 0 **Exit Output**
 Enter the output number to turn on when an exit delay time starts in any area of the system. The output turns off when the area arms or when the arming has been stopped. Enter 0 (zero) to disable.
- 11.10** READY OUT: 0 **Ready Output**
 Enter the output number to turn on when all disarmed burglary zones are in a normal state. The output is turned off when any disarmed burglary type zone is in a bad state. Enter 0 (zero) to disable. This output is not compatible with Cutoff Outputs.
- 11.11** PH TRBL OUT: 0 **Telephone Trouble Output**
 Enter the output number to turn on when the phone line monitor on the panel phone line is lost. Enter 0 (zero) to disable this output.
- 11.12** LATE CLS OUT: 0 **Late To Close Output**
 Enter the output number to turn on at the expiration of a Closing schedule. The output activates simultaneously with the CLOSING TIME! keypad display. The output is turned off when the area is armed, the Closing is extended, or the schedule is changed. Enter 0 (zero) to disable this output.
- 11.13** DVC FAIL OUT: 0 **Device Fail Output**
 Enter the output number to turn on when an addressed device fails to respond to polling from the panel. A Missing Device report is sent to the receiver. The output is turned off when the device responds to polling or is removed from programming in the system. Enter 0 (zero) to disable this output and LX-Bus™ device fail reporting to the receiver. If any addressed device is unsupervised, this output cannot be used.
- 11.14** SNSR RST OUT: 0 **Sensor Reset Output**
 Enter the output number to turn on when a Sensor Reset is performed at a keypad. The output turns off automatically 5 seconds later. This function can be used to reset smoke detectors that are operated by an external power supply through a Model 716 Output Expander Module. Enter 0 (zero) to disable this output.

OUTPUT OPTIONS

11.15

CLS WAIT OUT: 0

Closing Wait Output

Enter the output number to turn on for approximately four (4) seconds when Closing Wait is programmed as YES and the panel successfully communicates the closing message at arming. If the closing message does not communicate successfully, this output does not turn on.

11.16

ARM-ALARM OUT: 0

Arm-Alarm Output

Enter the output number to turn on steady when any area of the system is armed. If an alarm occurs causing the keypads to turn Red, this output pulses and continues to pulse for approximately five (5) minutes after the panel is disarmed. Enter 0 (zero) to disable.

Wireless Outputs

- The Arm-Alarm Output is compatible with the Model 1117 Wireless LED Annunciator and the Model 1116 Wireless Relay Output connected to a Model 572 Indicator LED.
- When the Model 1117 is battery operated, the LED is off when the system is armed to conserve battery life. If an alarm occurs, the output flashes quickly.
- When using the Model 1116 connected to a Model 572, the LED is on when the system is armed. If an alarm occurs, the output pulses.
- To operate the Arm-Alarm output within one second, program a fast response number from 480 to 499. Fast response operation reduces overall wireless output battery life.
- To operate the Arm-Alarm output within 15 seconds, program a slow response number from 450 to 474. Slow response operation increases overall wireless output battery life.

11.17

SUPV ALM OUT: 0

Supervisory Alarm Output

Enter the output number to turn on when a supervisory zone type is placed into an alarm. The output turns off when all supervisory type zones are restored to normal. Enter 0 (zero) to disable. Default is 0.

Output Information

- 12.1** OUTPUT INFO **Output Information**
This section allows you to program wireless outputs and name wired outputs.
- 12.2** OUTPUT NO. X X X **Output Number**
Enter an output number. Entry range is 1 to 6, 450 to 474, 480 to 499, 500 to 599. In order for wireless output troubles to display at a keypad, the keypad address must be specified at the Auxiliary 1 Zones prompt in the Status List programming.
- 12.3** OUTPUT NAME **Output Name**
This section allows you to define a 32 character alphanumeric name for any output numbers. The name can display on the keypad when a user performs the browser feature at Outputs On/Off. See the XR500/XR100 User's Guide (LT-0683CAN) Appendix for browser operation.
- 12.4** OUTPUT REAL-TIME STATUS NO YES **Output Real-Time Status**
Selecting YES allows Real-Time Status reports, such as Output ON, OFF, PULSE, or TEMPORAL to be sent using PC Log reports. Selecting NO disables Real-Time Status for this output device. Default is NO.
- 12.5** SERIAL#: XXXXXXXX **Serial Number**
This option and the next option only display when the output number entered is for a wireless output. Enter the eight-digit serial number found on the wireless device.
- ALREADY IN USE OUTPUT NO: XXX This message displays when the serial number is already programmed for another output. The programmed output number displays.
- 12.6** SUPRVSN TIME: 240 **Supervision Time**
Press any top row key to select the supervision time required for the wireless output. Press COMMAND to accept the default time. Default is 240 minutes.
- SELECT MINUTES:
0 3 60 240 **Note:** Refer to the Wireless Check-in and Supervision Time Definitions section of the Appendix for supervision information.
- Press the Select key under the required number of minutes. The wireless output must check in at least once during this time or a missing condition is indicated for that output. Zero (0) indicates an unsupervised transmitter.
- The 3 minute supervision time is only available if using an 1135 Wireless Siren.
- Note:** When the panel is reset, a receiver is installed or powered down and powered up, or programming is complete, the supervision timer restarts for all wireless outputs.
- 12.7** TRIP WITH PANEL BELL NO YES **Trip with Panel Bell Option**
This option displays when the wireless device is an 1135 wireless siren. Select YES to have the 1135 wireless siren follow the panel's bell output cadence for the zone type and bell cutoff time up to 15 minutes. Default is YES.

Output Groups

13.1

OUTPUT GROUPS

Output Groups

This function allows you to assign outputs to groups. Output groups can be assigned to other areas of programming such as Output Options or Alarm Action of Zone Information, just like single outputs are assigned. This allows the entire group of outputs to turn on and off as required by the programming option.

13.2

GROUP NO: -

Group Number

Enter a group number from 1 to 20. Up to 20 different groups may be assigned.

13.3

GROUP NAME X X

Group Name

The group name displays. To change the default name, press any top row Select key then enter up to 32 characters for the group name. Press COMMAND to enter the outputs to be assigned to the group.

13.4

OUTPUT NO 1: 0

Output Number

OUTPUT NO 2: 0

OUTPUT NO 3: 0

OUTPUT NO 4: 0

OUTPUT NO 5: 0

OUTPUT NO 6: 0

OUTPUT NO 7: 0

OUTPUT NO 8: 0

Enter the Output number. Entry range is 1 to 6, 450 to 474, 480 to 499, 500 to 599 (outputs), D1 to D8 (doors), and G1 to G20 (groups). The maximum number of outputs that can be assigned to a specific group is eight.

An output group may be assigned as one of the output numbers in another output group.

Example: Output Group 1 consists of only four assigned outputs. Output Group 1 could be assigned as one output in Output Group 2. Output Group 2 could still have 7 other outputs assigned to that group. When Output Group 2 is turned on, 11 outputs could be turned on. This allows Output Groups to be assigned within other Output Groups providing many combinations.

Output groups 1 to 10 can be assigned by a user profile for applications such as elevator control. See the XR500/XR100 User's Guide (LT-0683CAN) Output Group section for additional information.

Output groups 11 to 20 cannot be assigned to a profile and are available for installation applications such as special lighting, etc. To assign these groups to a profile, use Remote Link™ or System Link™ software from DMP.

Menu Display

14.1

MENU DISPLAY

Menu Display

Menu Display allows you to select at which keypad addresses the user can access the following functions.

To select a keypad, enter the device number (keypad address) using the digit keys on the keypad. When a keypad is selected, an asterisk appears next to the keypad address. Enter the number again to deselect the keypad. Refer to the Multiple Displays section at the beginning of this document.

14.2

ARMED STATUS:

Armed Status

1	2	3	4
5	6	7	8

Enter the keypad addresses (1 through 8) that show the armed areas. The User Menu Armed Areas function also displays the custom area name you enter in Area Information.

14.3

TIME DISPLAY:

Time

Enter the keypad addresses that can display the time and day of the week.

14.4

ARM/DIS DISPLAY:

Arm/Disarm

Enter the keypad addresses from which users can arm and disarm areas.

Status List

15.1 | | |-------------| | STATUS LIST | |-------------| **Status List**

This function allows you to select the zone alarms and troubles, and system monitor troubles displayed at the keypads. The Status List function operates automatically when the keypad is not performing any other function.

The keypad stays in the Status List until the user arms or disarms or selects a menu option. Status List alternates with the Armed Status on keypad addresses selected in the **Menu Display - Armed Status** section. You can choose to have System Monitor troubles placed in the list, the different zone types placed in the list, and at which keypad addresses they display.

To select a keypad, enter the device number (keypad address) using the digit keys on the keypad. When a keypad is selected, an asterisk appears next to the keypad address. Enter the number again to deselect the keypad. Refer to the Multiple Displays section at the beginning of this document.

15.2 | | |------------------| | DISPLAY KEYPADS: | |------------------| **Display Keypads**

This option defines which keypad addresses display the various status information. Any combination of addresses can be entered to display the status items that follow. If you do not want a particular status item to display, do not enter any addresses.

15.3 | | |------------------| | SYSTEM TROUBLES: | |------------------| **System Monitor Troubles**

1	2	3	4
5	6	7	8

Specifies the keypad addresses (1 through 8) where any trouble on a System Monitor displays. The System Monitors include the following:

- AC Power
- Battery Power
- Closing Check
- Panel Box Tamper
- Phone Line 1
- Phone Line 2 (requires the 893A Dual Phone Line Module)
- Wireless Receiver Trouble
- Wireless Jamming Trouble or Alarm

The System Monitor name is placed in the Status List and the keypad steady trouble buzzer sounds. The buzzer remains on until any keypad top row Select key is pressed. The name remains in the list until the condition is restored. The buzzer sounds at 10:00 am daily until the system trouble is cleared from the Status List.

15.4 | | |-------------| | FIRE ZONES: | |-------------| **Fire Zones**

1	2	3	4
5	6	7	8

Specifies the keypad addresses (1 through 8) where all fire zone alarms and troubles display. The zone name displays and, if it is a trouble condition, the keypad steady trouble buzzer sounds. The buzzer remains on until any top row Select key is pressed and a user code is entered. If a trouble condition remains in the display, the buzzer sounds at 10:00 am daily until the trouble is cleared from the Status List.

When using LCD Keypads, the panel provides distinct speaker tones from the keypad for Fire:

On - Fire zone alarm and Bell Output or Fire Bell Output is ON.

Off - Alarm Silence

15.5

BURGLARY ZONES:			
1	2	3	4
5	6	7	8

Burglary Zones

Specifies the keypad addresses (1 through 8) where all burglary zone alarms and troubles display. Burglary zones include Night, Day, and Exit type zones. Burglary zone troubles remain in the list until the zone restores. All keypads are selected by default.

For zone alarms, only the last burglary zone tripped remains in the list. The alarm remains in the list until another burglary zone goes into alarm, any area of the system is disarmed. This ensures that if a burglary is in progress the last zone tripped remains in the list even if the zone is restored.

The keypad buzzer sounds for one second on burglary alarms.

When using LCD Keypads, the panel provides distinct speaker tones from the keypad for Burglary:

On - Burglary zone alarm and Bell Output or Burglary Bell Output is ON.

Off - Alarm Silence.

You can further define which keypad address shows a Burglary Zone event by entering that area number in the Display Areas menu during Device Setup.

15.6

SPRVISORY ZONES:			
1	2	3	4
5	6	7	8

Supervisory Zones

Specifies the keypad addresses (1 through 8) where all supervisory zone alarms and troubles display. Supervisory zones are entered in the status list and sound the keypad buzzer until a valid user code is entered at any keypad address. If a trouble condition remains in the display, the buzzer sounds at 10:00 am daily until the supervisory trouble is cleared from the Status List.

15.7

PANIC ZONES:			
1	2	3	4
5	6	7	8

Panic Zones

Specifies the keypad addresses (1 through 8) where all panic zone alarms and troubles display. The name of the zone remains in the list until the zone restores. The keypad buzzer does not sound for panic alarms or troubles.

15.8

EMERGENCY ZONES:			
1	2	3	4
5	6	7	8

Emergency Zones

Specifies the keypad addresses (1 through 8) where all emergency zone alarms and troubles display. The name of the zone remains in the list until the zone restores. The keypad buzzer does not sound for emergency alarms or troubles.

15.9

AUX 1 ZONES:			
1	2	3	4
5	6	7	8

Auxiliary 1 Zones

Specifies the keypad addresses (1 through 8) where all Auxiliary 1 zone alarms and troubles display. The name of the zone remains in the list until the zone restores. The keypad buzzer does not sound for Auxiliary 1 alarms or troubles.

You can further define which keypad address shows an Auxiliary 1 Zone event by entering that area number in the Display Areas menu during Device Setup.

15.10

AUX 2 ZONES:			
1	2	3	4
5	6	7	8

Auxiliary 2 Zones

Specifies the keypad addresses (1 through 8) where all Auxiliary 2 zone alarms and troubles display. The name of the zone remains in the list until the zone restores. The keypad buzzer does not sound for Auxiliary 2 alarms or troubles.

You can further define which keypad address shows an Auxiliary 2 Zone event by entering that area number in the Display Areas menu during Device Setup.

15.11

COMM PATH TRBL:		
ALL	NO	YES

Communication Trouble

Specifies when communication troubles are displayed on keypads that are programmed to display System Monitor Troubles. Default is NO.

Select YES to display communication trouble when any communication path fails.

Select ALL to display communication trouble only when all paths have failed.

PC Log Reports

- 16.1** PC LOG REPORTS **PC Log Reports**
This section allows you to program the types of PC Log Reports the panel sends through the J1 network connector directly on the XR100N panel. The reports include information such as the type of activity, time and date of the activity, and user name and number. These data reports can be accessed from a PC using the Advanced Reporting Module.
Note: The network connection that sends PC Log Reports is not monitored for network trouble. The PC Log Reports option should NOT replace the primary communication method or act as a backup communication method.
If there is trouble with the network connection, the panel continues to attempt to send the PC Log Reports until the connection is reestablished. The panel then sends the reports. A Network Trouble message is **NOT** sent if the connection is lost since this report tool is not designed to be monitored by a receiver. The PC Log Reports have the lowest priority of panel reports sent.
Note: To enable remote programming direct connection operation with the panel through the LX header (J22), do not enter a PC Log Address and set all report options to NO. Refer to the XR100 Series Canadian Installation Guide (LT-0899CAN) for J22 connection and operation.
- 16.2** COMM TYPE: **NONE** **Communication Type**
 NONE NET Select the Communication Type to send the PC Log Reports. Default is NONE.
- 16.3** NET IP ADDRESS **Net IP Address**
This option displays when the Communication Type for PC Log Reports is NET. Enter the IP address containing up to 16 characters. The Net IP Address must be unique and cannot be duplicated on the network. Enter all 12 digits and leave out the periods. For example, enter IP address 192.168.0.250 as 192168000250. The periods display automatically.
- 16.4** NET PORT **2001** **Net Port**
This option displays when Communication Type for PC Log Reports is Net. Enter the Port number. Valid numbers are from 0 to 65535. Default is 2001.
- 16.5** ARM/DIS **NO** YES **Arm and Disarm Reports**
Sends arming, disarming and Late to Close events. Includes the area number, name and action, the user number and name, and the time and date.
- 16.6** ZONE **NO** YES **Zone Reports**
Sends changes in the status of active zones. Includes the zone number, name, type, the action (alarm, trouble, bypass, etc.), user number (if applicable), and area name. For a Walk Test, Verify and Fail messages are sent for each zone.
- 16.7** USR CMDS **NO** YES **User Command Reports**
Sends user code changes, schedule changes, and door access denied events.
- 16.8** DOOR ACS **NO** YES **Door Access Reports**
Sends door access activity: door number, user number and name, and time and date.

16.9

SUPV MSG	NO	YES
----------	----	-----

Supervisory Reports

Sends system monitor reports, such as AC and battery, and system event reports. Supervisory Reports also sends the following reports:

- Abort
- System Recently Armed
- *Late to Close
- Exit Error
- Alarm Bell Silenced
- Only sent as a Supervisory Report if **Area Schedules** is not enabled, **Closing Check** is enabled, and an opening/closing schedule has been programmed.
- Ambush
- Unauthorized Entry

Note: To send these reports to the PC Log, you must enable SUPV MSG.

16.10

PC LOG REAL-TIME STATUS	NO	YES
----------------------------	----	-----

PC Log Real-Time Status

Select YES to send Real-Time Status reports for zones, doors, and outputs. The specific reports must also be selected by individual zone or output. The Real-Time Status messages are sent to a PC running a graphic display software. Default is NO.

The messages that can be sent are:

- Door Open with zone number
- Door Closed with zone number
- Door Open with door number
- Door Closed with door number
- Output On
- Output Off
- Output Pulse
- Output Temporal

Area Information

17.1

AREA INFORMATION

Area Information

Allows you to assign functions to the different areas in the system. All non-24-hour zones must be assigned to an active area. See Zone Information.

You activate an area by assigning it a name. See Area Name. A name is given to each active area in place of a number to assist the user during arming and disarming. The Armed Status display is 1 2 3 4 5 6 7 8.

17.2

EXIT DELAY: 60

Exit Delay

Enter the exit delay time for all Exit type zones in this area. When the exit delay time starts, all activity on that zone and other non-24-hour zone types in the area is ignored until the exit delay expires. The keypad displays the Exit Delay time countdown and annunciates the Exit Delay tone at 8 second intervals until the last 10 seconds when annunciation is at 3 second intervals.

The exit delay can be from 30 to 250 seconds. Default is 60 seconds.

During Exit Delay, if an exit zone trips, then restores, and trips again, the Exit Delay timer restarts. This restart can occur only once. The Exit Delay restart is disabled when programmed for High Line Security operation.

Exit Error Operation: At arming, when an entry/exit zone (EX) is **faulted** at the end of the exit delay then one of two sequences occur:

For Entry Delay 1 EX type zones:

- the bell sounds for the length of time set in Bell Cutoff programming.
- the Entry Delay operation starts requiring code entry to disarm
- if not disarmed, a zone alarm and an exit error are sent to the receiver.

For Entry Delay 2-4 EX type zones:

- the zone is force armed and a zone force arm message is sent to the receiver
- an Exit Error is sent to the receiver
- the bell sounds for the length of time set in Bell Cutoff programming

17.3

BURG BELL OUT: 0

Burglary Bell Output

Enter the output number (0 to 6, 500 to 599, G1 to G20, or D1 to D8) that is turned on any time a Burglary type zone is placed in alarm. The output is turned off when you disarm any area and no other Burglary type zones are in alarm. The output can also be turned off using the Alarm Silence option in the User Menu or by entering a user code with the authority to silence alarms. The duration of this bell output follows the time entered in the System Options>Bell Cutoff Time prompt. See the **Output Options - Bell Cutoff Time** section. If Bell Test is selected **YES**, the Burglary Bell Output entered here is turned on for two seconds each time the system is armed.

17.4

O/C RPTS NO YES

Opening/Closing Reports

This option allows an Opening report to be sent to the receiver whenever any area is disarmed. A Closing report is also sent to the receiver when any area is armed.

- 17.5** CLS CHK **NO** YES **Closing Check**
 Select YES to enable the panel to verify that all areas in the system are armed after permanent or extended schedules expire. If the Closing Check finds any areas disarmed past the scheduled time, the keypads selected to display System Trouble Status displays CLOSING TIME! and emits a steady beep. When Area Schedules is set to YES in Area Information, the specific area and name display followed by – LATE. When Auto Arm is NO, if within ten minutes the system is not armed or if the schedule is not extended, a Late to Close report is sent to the SCS-1/SCS-1R Receiver. When Auto Arm is YES, the area arms. See Automatic Arming section. If the area becomes disarmed outside of any schedule, the Closing Check sequence occurs after the Late Arm Delay time. See Late Arm Delay. When Closing Check is NO and Auto Arm is YES, the system immediately arms when the schedule expires. No warning tone occurs. In addition, when Closing Check is NO, the option to extend a schedule does not display when the schedule expires.
- 17.6** CLS CODE **NO** YES **Closing Code**
 When YES is selected, a code number is required for system arming. If NO is selected, a code number is not required for system arming.
- 17.7** ANY BYPS **NO** YES **Any Bypass**
 When YES is selected, zones can be bypassed without a code number during the arming sequence. A code number is always required to use the Bypass Zones option from the menu.
- 17.8** AREA SCH **NO** YES **Area Schedules**
 Select YES to allow each area to set its own shift schedules 1 to 4. Enter NO to provide one set of schedules for this system.
Note: Area Schedules are not designed to operate with All/Perimeter or Home/Sleep/Away systems.
- 17.9** AREA NO: - **Area Number**
 Enter the number of the area to program. After entering the area number, press COMMAND to enter the area name. Only Area systems allow the area name to be changed.
Note: When All/Perimeter or Home/Sleep/Away is selected as the system type, the Area Number does not display.
- 17.9.1** INT PERIM **All/Perimeter Programming**
 When All/Perimeter is selected as the system type, program the Interior and Perimeter areas as needed.
- 17.9.2** INT BDRM PERIM **Home/Sleep/Away Programming**
 When Home/Sleep/Away is selected as the system type, program the Interior, Bedroom, and Perimeter areas as needed.

AREA INFORMATION

17.10

* UNUSED *

Area Name

The area name can be up to 32 alphanumeric characters. To add an area name to the system, press any Select key and then enter up to 32 characters for the new area name. Press COMMAND to continue. For instructions on entering alphanumeric characters see section 1.7 Entering Alpha Characters. Inactive areas are marked * UNUSED *. Only systems programmed for Area has the option available to change the area name.

To mark an active area unused, press any top row Select key to delete the old name, then press the COMMAND key. The programmer automatically programs the name as *UNUSED*. If you have already cleared Area Information during Initialization, all areas are marked * UNUSED *. See Initialization section.

Home/Sleep/Away with Guest systems display the area name, but the names cannot be changed. The following are the display names that appear on the keypad:

Area	Display
1	Perimeter
2	Interior

Area	Display
3	Bedrooms
4	Guest Perimeter

Area	Display
5	Guest Interior
6	Guest Bedrooms

17.11

ACCOUNT NO: 12345

Account Number

Enter the account number to be sent to the receiver for this area. Choose an account number compatible with the Communication Type selected in Communications. The default Account Number is the one previously entered in Communications. This account number is used when sending area messages and events to the central station. See the Area Account Number Messages in the Appendix.

17.12

AUTO ARM NO YES

Automatic Arming

Select YES to allow this area to arm automatically according to permanent, temporary, or extended schedules. If no schedules are programmed, the area auto arms every hour.

If closing check is selected as YES, the automatic arming function does not take place until the expiration of a ten minute Closing Check delay. See Closing Check. If the area has been disarmed outside of any permanent or temporary schedule, the closing check sequence occurs one hour after the area is disarmed.

At arming, bad zones are handled according to the option selected in section Bad Zones. If a closing report is sent, the user number is indicated as SCH on the SCS-1R Receiver. NO disables automatic arming for this area.

17.13

BAD ZONES: BYP

Bad Zones

At the time of automatic arming, some zones in the area may not be in a normal condition. This option allows you to program the panel response to these bad zones. This option does not display if AUTO ARM is NO.

BYP FORC REF

BYP - All bad zones are bypassed. A report of the bypass is sent to the receiver if Bypass Reports is YES. The report indicates SCH as the user number.

FORC - All bad zones are force armed. Zones force armed in a bad condition are capable of restoring and reporting an alarm if tripped. A forced zone report is transmitted if Bypass Reports is YES. The report indicates SCH as the user number.

REF - The automatic arming is refused and no arming takes place. A No Closing report is sent to the receiver regardless of the Closing Check selection.

17.14

AUTO DIS NO YES

Automatic Disarming

NO disables automatic disarming by schedule for this area. When YES is selected, the area automatically disarms according to permanent or temporary schedules. If an opening report is sent to the receiver, the user number is indicated as SCH.

- 17.15** ARMED OUTPUT: 0 **Armed Output Number**
 Enter the output to turn on when this area is armed. If an exit delay is used for this area, the Armed Output turns on at the start of the exit delay. The output is turned off when this area is disarmed. The output cannot be turned on from the User Menu Outputs On/Off option.
- 17.16** LATE OUTPUT: 0 **Late Output Number**
 Enter the output to turn on when this area is not armed by its scheduled time and Area Late or Closing Time displays at a keypad and the keypad buzzer is on. The output is turned off when the keypad buzzer is silenced by pressing any key. Default is 0 (zero).
- 17.17** LATE/ARM DLY: 60 **Late Arm Delay**
 Enter 4 to 250 minutes to delay before automatic re-arming occurs after the area becomes disarmed outside of schedules. See Closing Check. Default is 60 minutes.
Note: The Late Arm Delay can be superseded by the Re Arm Delay setting of the User Profile assigned to the user who disarmed the area. Refer to the Re Arm Delay section in the XR100 Series Canadian User's Guide (LT-0683CAN).
- 17.18** COMMON NO YES **Common Area**
 Select **YES** to enable this area to operate as a common area. This area is armed when the last area in the system is armed and is disarmed when the first area in the system is disarmed. You can have multiple common areas in each system. For the common area to work properly, do not assign the common area to any user code. When a user code can arm and disarm the common area from a keypad at any time, the common area does not function as a common area.
- 17.19** ARM FIRST NO YES **Arm First Area**
 Select **YES** to enable this area to operate as an Arm First area. This area is automatically armed when any non-Arm First area assigned to the same keypad is armed but does not disarm when other areas become disarmed. Assign areas to keypads using the Display Areas option in Device Setup programming. You can have multiple Arm First areas in a system and divide them among keypads if needed. If an Arm First area has faulted zones that cannot be bypassed, arming stops and the areas are not armed. Correct the problem with the Arm First area and then begin the arming process again. Default value is **NO**.
Note: The Arm First automatic arming only occurs when arming from a keypad. Arming from a zone, schedule, or remotely is not affected and Arm First areas do not automatically arm.

ZONE INFORMATION

Zone Information

18.1 ZONE INFORMATION **Zone Information**

Zone Information allows you to define the operation of each protection zone used in the system. All protection zones, whether located on a command processor panel, Security Command keypad, or zone expander are programmed the same way.

18.2 ZONE NO: - **Zone Number**

Enter the number of the zone you intend to program. Available zone numbers are shown in the table below. The keypad zone numbers begin with the keypad address and are followed by the particular zone from that keypad. For example, a 7073 at keypad address 7 would provide zones 71, 72, 73, and 74.

Press COMMAND to enter a zone name.

Address	Programming Zone Number
Panel	1-10
1	11-14
2	21-24
3	31-34
4	41-44
5	51-54
6	61-64
7	71-74
8	81-84
1100 Series Key Fob	400-449
LX-Bus 1	500-599

Note: For 1100 Series Key Fob zones (400-449), programming continues at the 1100 Series Key Fobs Section.

18.3 * UNUSED * **Zone Name**

Zone names can have up to 32 alphanumeric characters. A name must be given to each zone in the system. The name can display at the keypads during arming and disarming so the user does not have to memorize zone numbers. Users can associate a zone name with a particular protection point. A zone that is not part of the system must be marked unused.

To add a zone name to the system, press any Select key and then enter up to 32 characters for the new zone name. Press COMMAND to continue.

To mark a zone unused, delete the old name by pressing a top row Select key, then press the COMMAND key. The programmer automatically programs the name as * UNUSED *. If you have already cleared Zone Information during Initialization, the zones are marked * UNUSED *.

18.4

ZONE TYPE: BLANK

Zone Type

The Zone Type defines the panel response to the zone being opened or shorted. This is called the Alarm Action. There are up to 13 possible alarm action responses depending on the zone type and any restrictions it may have. See the Zone Type chart in the Appendix.

When you assign a Zone Type to a zone, automatic zone responses are made. There are 12 Zone Types to choose from. Application descriptions for each zone type can be found in the Appendix of this manual.

To enter a new Zone Type, press any Select key. The display lists all of the available Zone Types four at a time.

-- NT DY EX

Blank, Night, Day, or Exit. Press COMMAND for additional zone types.

FI PN EM SV

Fire, Panic, Emergency, or Supervisory. Press COMMAND for additional zone types.

A1 A2 FV AR

Auxiliary 1, Auxiliary 2, Fire Verify, or Arming (keyswitch). Press the Back Arrow key to display the previous zone types. When the Zone Type you want displays, press the Select key beneath it.

If you select Blank, Night, Day, Exit, Auxiliary 1, Auxiliary 2, or Arming as the Zone Type, the zone must be assigned to an active area. If you select Fire, Fire Verify, Panic, Emergency, or Supervisory as the Zone Type, it is a 24-hour zone that is always armed and no area assignment is needed.

Zone Type Specifications

The panel contains 12 default zone types for use in configuring the system. These zone types provide the most commonly selected functions for their applications. All zone types except the Arming zone type can be customized by changing the options listed below.

Refer to the Appendix for complete zone type descriptions.

18.5

AREA NO: -

Area Assignment

Enter the area number where the Night, Day, Exit, Auxiliary 1, or Auxiliary 2 zone is being assigned. For an Area system, area numbers 1-8 can be assigned. For a Home/Sleep/Away with Guest system, area numbers 1-6 can be assigned.

AREA: PERIMETER

In an All/Perimeter or Home/Sleep/Away system, the currently selected area, Perimeter, Interior, Bedroom displays.

INT PERIM

On an All/Perimeter system, select INT to program zones for the interior area and select PERIM to program zones for the perimeter area.

INT BDRM PERIM

On a Home/Sleep/Away system, select INT to program zones for the interior area, select BDRM to program zones for the bedroom area, and select PERIM to program zones for the perimeter area.

18.6

FIRE BELL OUT: 0

Fire Bell Output

This output (1 to 6, 500 to 599, G1 to G20, or D1 to D8) is turned on any time a Fire, Fire Verify, or Supervisory zone is placed in alarm. The output is turned off by any the following actions:

- When the User Menu Alarm Silence function is performed.
- When a valid user code is entered to silence the bell.
- When the Silence key is pressed on the 630F Remote Fire Command Center.
- Using the Outputs On/Off function in the User Menu.
- The expiration of the Bell Cutoff time.

This output can be connected to a lamp, LED, or buzzer using the DMP Model 716 Output Expansion Module.

ZONE INFORMATION

18.7

ARM/DIS AREAS

Arming Zone Area Assignment

In an Area or Home/Sleep/Away with Guest system, if the zone has been programmed as an Arming Type (AR), enter the areas that the zone controls.

When the zone changes from normal to shorted, the programmed areas toggle between the armed or disarmed condition using the Style programming below. When restored to normal, no action occurs. When the zone is opened from a normal (disarmed) state, a trouble is reported. When opened from a shorted (armed) state, an alarm is reported and the zone is disabled until you disarm the area(s) from either a keypad or Remote Link™ computer.

To visually indicate the armed state of the area(s), you can assign an Armed Output to individual areas and use remote LEDs at the keyswitch. The LED turns on or off to indicate to the user the armed state of the area(s).

ARM AREAS: PERIM

In an All/Perimeter or Home/Sleep/Away system, this option specifies the areas to be armed by the Arming Type zone. For All/Perimeter systems, choose PERIM or ALL, for Home/Sleep/Away or Home/Away systems, choose HOME, SLEEP, or AWAY.

PERIM ALL

Perimeter/All - Specify whether the arming zone arms just the Perimeter (PERIM) or the Perimeter and Interior areas (ALL) for All/Perimeter systems. When disarming, all areas are disarmed.

HOME SLEEP AWAY

Home/Sleep/Away - Specify whether the arming zone arms the Perimeter (HOME), the Perimeter and Interior (SLEEP), or all three areas (AWAY). When disarming, all areas are disarmed.

Arming Zone Operation

If any bad zones are present when the Arming zone is shorted, the LED delays lighting for 5 seconds. If during the 5-second delay the Arming zone is shorted again no arming takes place. If 5 seconds expire without the zone shorting again or restoring to normal, the areas arm and bad zones are force armed. To allow bad zones to be force armed, the Any Bypass option must be set to YES. If Any Bypass option is set to NO, arming does not occur. See the Area Information - Any Bypass section. A priority zone cannot be force armed.

18.8

STYLE:

Style

This option specifies the style for the arming/disarming operation. The default style is TGL (toggle). Press any Select key to display the STYLE options. To view more style options press the COMMAND key.

TGL ARM DIS STEP

TGL (Toggle) - When the zone changes from normal to shorted, the programmed areas toggle between the armed or disarmed condition. When restored to normal, no action occurs. When the zone opens from a normal (disarmed) state, a trouble is reported. When opened from a shorted (armed) state, an alarm is reported and the zone is disabled until you disarm the area(s) from either a keypad or Remote Link.

ARM - When the zone is shorted, the programmed areas are armed. When restored to normal, no action occurs. When the zone is opened from a normal (disarmed) state, a trouble is reported. When opened from a shorted (armed) state, an alarm is reported.

DIS (Disarm) - When programmed, a short disarms the programmed areas. When restored to normal, no action occurs. When the zone is opened from a normal (disarmed) state, a trouble is reported.

STEP - A short arms the areas and beeps the keypads once. A normal condition causes no action. An open condition disarms the programmed areas and beep the keypads for one second.

Note: This arming style is designed for wireless arming pendants. When using a arming/disarming keyswitch locate the keyswitch within the protected area.

MNT

MNT (Maintain) - When the zone is shorted, the programmed areas are armed. When restored to normal, the programmed areas are disarmed and any alarm bells are silenced. When the zone is opened from a normal (disarmed) state, a trouble is reported. If opened from a shorted (armed) state, an alarm is reported and the zone is disabled until you disarm the area(s) from either a keypad or Remote Link.

18.9

NEXT ZN?	NO	YES
----------	----	-----

Next Zone

Select YES to terminate zone programming. The display returns to Zone Number, allowing you to enter a new zone number. Select NO to make alterations to the Alarm Action for a zone. Alarm Action is defined beginning with section 15.12.

To program zones for wireless operation, select NO at the NEXT ZONE - NO YES option. The WIRELESS NO YES option displays. If the zone you are programming is intended for wireless devices, select YES. Select NO to continue programming non-wireless zones in the 500 to 599 range.

- Zones 400 to 449 can be programmed for 1100 Series Key Fobs.
- Zones 500 through 599 can be programmed for DMP Wireless.

DMP Wireless

For a DMP 1100X Wireless Receiver set the House Code to 1-50. See House Code programming in System Options. Zones 500 through 599 can be programmed as Wireless zones. Set the XR100 Series Canadian panel J23 jumper to X to enable DMP Wireless operation. After power-up, briefly reset the panel using the J16 jumper to activate Wireless operation. Refer to the XR100 Series Canadian Installation Guide (LT-0899CAN).

For an 1100 Series Key Fob see section 15.11.

NOTE: All wireless programming is stored in the XR100 Series Canadian panel. The 1100X Wireless Receiver obtains the necessary programming information from the panel each time the receiver powers up, when the programmer STOP routine is selected or the panel is reset. The receiver memory refresh takes up to 10 seconds to complete depending on the number of wireless zones programmed and the Red LED remains on during this time. Normal receiver operation is inhibited during the memory refresh period.

18.10

ZONE INFORMATION WIRELESS?	NO	YES
-------------------------------	----	-----

Wireless

Select YES to program this zone as a DMP wireless zone. You must program the wireless House Code prior to adding DMP wireless zones to the system. See House Code programming in System Options. Default is NO.

18.10.1

TRANSMITTER SERIAL#: XXXXXXXX

Serial Number Entry

Enter the eight-digit serial number found on the wireless device.

ALREADY IN USE ZONE NUMBER: XXX

This prompt displays when the serial number is already programmed for another zone. The programmed zone number displays.

18.10.2

TRANSMITTER CONTACT:XXXXXXXX

Contact

This option displays if the serial number entered is for an 1101 or 1103 Universal Transmitter or 1114 Wireless Four-Zone Expander. Press any top row key to select the contact.

TRANSMTR CONTACT INT EXT

This option displays when programming an 1101 or 1103 Transmitter. Select INT to use the internal reed switch contacts. Select EXT to connect an external device to the 1101 or 1103 terminal block. Default is INTERNAL.

By allowing both of the Model 1101 or 1103 transmitter contacts (INT and EXT) to be used at the same time, two zones may be programmed from one transmitter. When using both contacts, you must use consecutive zone numbers. Zones 531 and 532 or zones 590 and 591 are acceptable zone assignments.

For example, program transmitter serial number 01345678 as Zone 521 with an INT contact type and Zone 522 with an EXT contact type. The same serial number is used for both zones.

ZONE INFORMATION

TRANSMTR CONTACT
1 2 3 4

This option displays when programming the 1114 Wireless Four-Zone Expander with four input contacts. The same serial number is used for all four contacts. Select the contact number to program. When using the contacts, you must use consecutive zone numbers. Default is Contact 1.

For example, use serial number 08345678 to program Contact 1 for Zone 561, Contact 2 for Zone 562, Contact 3 for zone 563, and Contact 4 for zone 564.

A tamper on the 1114 is transmitted as the zone number assigned to Contact 1.

ALREADY IN USE
ZONE NUMBER: XXX

This message displays when the Contact is already programmed for another zone. The programmed zone number displays.

ZONE INFORMATION
NORM OPN NO YES

This option only displays when EXT is selected as the Contact type. For external devices connected to the 1101 or 1103 terminal block, select NO to use normally closed (N/C) contacts. Select YES to use normally open (N/O) contacts. Default is NO.

18.10.3

TRANSMITTER
SUPRVSN TIME: 240

Supervision Time

Press any top row key to select the supervision time required for the wireless zone. Press COMMAND to accept the default time. Default is 240 minutes.

SELECT MINUTES:
0 3 60 240

Press the Select key under the required number of minutes. The transmitter must check in at least once during this time or a missing condition is indicated for that zone. 1100 Series transmitters automatically checkin based on the supervision time selected for the wireless zone, no additional programming is needed. If two zones share the same transmitter, the last programmed supervision time is stored as the supervision time for both zones. Zero (0) indicates an unsupervised transmitter.

The 3 minute supervision time is only available for zone types of Fire (FI), Fire Verify (FV), and Supervisory (SV).

Note: When the panel is reset or a receiver is installed or powered down and powered up, the supervision timer restarts for all wireless zones.

18.10.4

LED OPERATION
NO YES

LED Operation

Select YES to turn on an 1142 Hold-up transmitter LED during Panic or Emergency operation. Select NO to turn the LED off during Panic or Emergency operation. The LED always operates when the transmitter case is open and the tamper is faulted. Default is YES.

18.10.5

DISARM DISABLE
NO YES

Disarm/Disable

Select YES to disable the zone tripped message (short) to the 1100X Series Receiver from the 1126 PIR transmitter during the disarmed period. When disabled, the 1126 only sends supervision, tamper and low battery messages during the disarmed period to extend transmitter battery life. Select NO to always send zone tripped messages in addition to supervision, tamper and low battery. Default is YES.

18.10.6

WIRELESS PIR
PULSE COUNT: 4

PIR Pulse Count

Select the number of infrared pulses (2 or 4) the 1126 PIR should sense before sending a short message to the 1100X Series Receiver. Default is 4.

18.10.7

WIRELESS PIR
SENSITIVITY: LOW

PIR Sensitivity

Select the sensitivity setting for the 1126 PIR. Selecting LOW sets the 1126 to operate at 75% sensitivity for installations in harsh environments. Selecting HIGH sets the PIR to maximum sensitivity. Default is LOW.

18.10.8

NEXT ZONE NO YES

Next Zone

Select YES to return to the ZONE NO: - prompt to program a new zone. Select NO to display the Alarm Action option.

1100 Series Key Fobs

For an 1100 Series Key Fob set the House Code to 1-50. See House Code programming in System Options. Only zones 400 to 449 can be programmed as 1100 Series Key Fob zones. Refer to the 1100 Series Key Fob Programming Sheet (LT-0706) and the 1100 Series Key Fob Install Guide (LT-0703) as needed. The following programming continues from the Zone Number Section when zone 400-449 is selected.

To operate arming and disarming properly, the Key Fob should be assigned to a User Number with appropriate area assignments, however, the User Number does not have to exist at the time the Key Fob is programmed. The Key Fob User Number can be added later by the User.

The following programming continues from the Zone Number section when zone 400-449 is selected.

18.11.1

KEY FOB USER
NUMBER: XXXX

Key Fob User Number

Enter the User Number (1-9999) used to identify the Key Fob user and their arming and disarming authority at the receiver and panel. Default is blank.

Displays when the User Number entered does not exist in User Code programming. The key fob can be added, but the user must eventually be created to cause the key fob to operate.

18.11.2

USER XXXX
NOT IN USE

TRANSMITTER
SERIAL#: XXXXXXXX

Key Fob Serial Number

Enter the eight-digit serial number found on the wireless device.

18.11.3

TRANSMITTER
SUPRVSN TIME: 0

Key Fob Supervision Time

Press any top row key to select the supervision time required for the key fob zone. Press COMMAND to accept the default time. Default is 0 for key fobs.

SELECT MINUTES:
0 60 240

Press the Select key under the required number of minutes. The key fob must check in at least once during this time or a missing condition is indicated for that zone. 1100 Series key fobs automatically checkin based on the supervision time selected for the wireless zone, no additional programming is needed. Zero (0) indicates an unsupervised transmitter.

Note: When the panel is reset or a receiver is installed or powered down and powered up, the supervision timer restarts for all wireless zones.

18.11.4

NO. OF KEY FOB
BUTTONS: X

Number of Key Fob Buttons

Enter the number of buttons (1, 2, or 4) on the Key Fob being programmed.

Note: If the key fob is a one-button model, programming continues at the Button Action section. Default button assignment for one-button key fobs is a Panic Alarm (PN) with no output assigned.

18.11.5

BUTTON:
TOP BTM LFT RGT

Key Fob Button Selection (Four Buttons)

This prompt only displays if the Key Fob being programmed is a four-button model. Press the Select key under the Key Fob button to program. The following list identifies the default button assignments:

- TOP Arming with no areas assigned
- BTM Disarming with no areas assigned
- LFT Panic Alarm (PN) with no output assigned
- RGT Arming with Area 1 assigned

18.11.6

BUTTON:
TOP BTM

Key Fob Button Selection (Two Buttons)

This prompt only displays if the Key Fob being programmed is a two-button model. Press the Select key under the Key Fob button to program. The following list identifies the default button assignments:

- TOP Arming with no areas assigned
- BTM Disarming with no areas assigned

ZONE INFORMATION

18.11.7

BUTTON ACTION: XXXXXXXX

Button Action

This option specifies the Button Action? for an individual Key Fob button. The default action displays. Press any Select key to display the Button Action? options. To view more options press the COMMAND key.

BUTTON ACTION? ARM DIS TGL STA

ARM (Arm) - Arms selected areas and force arms bad zones.

DIS (Disarm) - Disarms selected areas.

TGL (Togl Arm) - Toggles arm/disarm for selected areas and force arms bad zones.

STA (Status) - Causes the Key Fob LED to indicate the arm/disarm status of the system.

BUTTON ACTION? PN PN2 EM EM2

PN (Panic) - Triggers a Panic zone type alarm with no restoral.

PN2 (Panic 2) - Triggers a Panic zone type alarm with no restoral when pressed simultaneously with any other Panic 2 button. No action occurs when pressed alone.

EM (Emerg) - Triggers an Emergency zone type alarm with no restoral.

EM2 (Emerg 2) - Triggers an Emergency zone type alarm with no restoral when pressed simultaneously with any other Emergency 2 button. No action occurs when pressed alone.

BUTTON ACTION? OUT RST UN

OUT (Output) - Causes an output to turn on steady, pulse, momentary, toggle or off.

RST (Snsr Rst) - Causes the panel to perform a standard Sensor Reset.

UN (Unused) - The button is not used and performs no action.

18.11.8

aaa BUTTON PRESS TIME: DDDDD

Button Press Time

This option specifies the amount of time (SHORT or LONG) the user must press the button before the key fob sends a message to the wireless receiver. The default press time displays. Press any Select key to set the Button Press Time for Arm, Disarm, Toggle, Status, Output, and Sensor Reset.

Note: The Button Press Time is not programmable on Panic (PN or PN2), Emergency (EM or EM2) or Unused (UN) zones. For those zones the button press time is always two (2) seconds.

BUTTON PRESS: SHORT LONG

SHORT - Press the button for one-half (1/2) second to send the message to the wireless receiver.

LONG - Press the button for two (2) seconds to send the message to the wireless receiver.

18.11.9

ARM/DIS AREAS:

1	2	3	4
5	6	7	8

Arm/Disarm Area Selection

In an Area system or Home/Sleep/Away with Guest system, this specifies the areas to be armed/disarmed by the Key Fob button being programmed. To select an area between 1 and 8, enter the area number using the keypad digit keys. Default is no areas enabled.

In order to arm or disarm selected areas, the Profile assigned to the User Number needs to have the same area numbers selected. Any area may be selected at Arm/Disarm Areas but only matching area numbers are armed or disarmed when the specific button is pressed. For example, in Areas selection, areas 1, 3, and 7 are selected. In the User Profile Arm and Disarm Areas, areas 1, 2, 4, and 7 are selected. When the user presses the button to Arm or Disarm area(s), only matching areas 1 and 7 Arm/Disarm.

Note: When more areas are selected at Arm/Disarm Areas than are authorized in the User Profile, in the future the user can be given access authority to additional areas through the User Profile without requiring additional panel programming to select Arm/Disarm Areas. See User Profiles in the Appendix or refer to the XR500/XR100 Series Canadian User's Guide (LT-0683).

ARM AREAS: PERIM

In an All/Perimeter or Home/Sleep/Away system, this specifies the area to be armed by the Key Fob button being programmed. For All/Perimeter systems, choose PERIM or ALL, for Home/Sleep/Away or Home/Away systems, choose HOME, SLEEP, or AWAY.

Note: Areas 3 and higher in an All/Perimeter system, and areas 4 and higher in a Home/Sleep/Away system are not available for use.

After selecting the areas, for one-button key fobs the Zone No.: prompt displays. For two-button or four-button key fobs, the Key Fob Button Selection option displays to program additional buttons.

18.11.10 OUTPUT NO: XXX

Output Number

You can specify a relay output to operate when OUT (Output), PN (Panic), PN2 (Panic 2), EM (Emergency), or EM2 (Emergency 2) is selected for a key fob Button Action and the button is pressed. Valid range is 1 to 6, 500 to 599, D1 to D8, or G1 to G20. For an output turned on by a PN, PN2, EM, or EM2 button action, the output turns off when any area is disarmed.

To enter an output number, press a top row Select key followed by the output number. Press the COMMAND key.

18.11.11 ACTION: XXXXXXXX

Output Action

This option allows you to define the Key Fob output operation (STD, MOM, TGL, OFF) when PN, PN2, EM, or EM2 is selected for a Key Fob Button Action and the button is pressed. For an output turned on by a PN, PN2, EM, or EM2 button action, the output turns off when any area is disarmed by Key Fob button press. The currently programmed action displays.

OUTPUT ACTION?
STD PLS MOM TGL

STD (Steady) - The output is turned on and remains on until the area is disarmed, an output cutoff time expires, or the output is reset from the keypad menu.

PLS (Pulse) - The output alternates one second on and one second off. **Note:** The pulsing rate for a Model 716 relay attached to the LX-Bus is 1.6 seconds.

MOM (Momentary) - The output is turned on only once for one second.

TGL (Toggle) - The output alternates between the armed and disarmed condition. When restored to normal, no action occurs. When the zone opens from a normal (disarmed) state, a trouble is reported. When opened from a shorted (armed) state, an alarm is reported and the zone is disabled until the area(s) is disarmed from either a keypad or Remote Link.

OUTPUT ACTION?
OFF

OFF (Off) - The output is turned off. If programmed, the output was turned on by some other means such as another button press, a zone action, or a schedule.

18.11.12 NEXT ZONE NO YES

Next Zone

Select YES to return to the ZONE NO: - prompt to program a new zone. Select NO to display the Alarm Action option.

Note: All wireless programming is stored in the XR500 Series panel. The 1100X Wireless Receiver obtains the necessary programming information from the panel each time the receiver powers up, when the programmer STOP routine is selected or the panel is reset. The receiver memory refresh takes up to 10 seconds to complete depending on the number of wireless zones programmed and the Red LED remains on during this time. Normal receiver operation is inhibited during the memory refresh period.

ZONE INFORMATION

18.12 Alarm Action

This option allows you to change any Zone Type standard definitions. When the Zone Type is specified, the Alarm Action for that zone is stored in memory.

If the Zone Type is Blank, Night, Day, Exit, Auxiliary 1, or Auxiliary 2 it is a non-24-hour zone and the Alarm Action programming begins with Disarmed Open.

If the Zone Type is Fire, Panic, Emergency, or Supervisory it is a 24-hour zone that is always armed and the Alarm Action programming begins with Armed Open.

The Fire Verify Zone Type functions the same as Fire Type, with the following exceptions: When a Fire Verify zone initiates an alarm, the panel performs a Sensor Reset. If any Fire Verify zone initiates an alarm within 120 seconds after the reset, an alarm is indicated. If an alarm is initiated after 120 seconds, the cycle is repeated and a zone fault report is sent to the receiver.

Do NOT program Fire Verify Zone Types for Zone Retard.

18.13 Disarmed Open

Defines the action taken by the panel when the zone is opened while the area is disarmed. There are three actions to define: Report to transmit, Relay Output to activate, and Relay Output action.

You must also make these selections for the Disarmed Short, Armed Open, and Armed Short zone conditions. Press COMMAND to continue.

18.14 Report to Transmit

Press any Select key to display the following report options: A, T, L, S, and - (dash).

ALARM - Select A to send an alarm report to the receiver and activate the bell output according to zone type. The zone name appears in the panel alarmed zones and status lists.

TROUBLE - Select T to send a trouble report to the receiver. The zone name appears in the panel alarmed zones and status lists.

LOCAL - When you select L, an alarm report is NOT sent to the receiver. The bell output activates and the zone name appears in the panel alarmed zones and status lists.

- (Dash) - When you select a - (dash), reports are NOT sent to the receiver. The bell output does not activate and there is no display in the panel alarmed zones or status list. Only the relay output selected in the next section operates.

DOOR PROPPED - Selecting D allows the following operation: The time programmed into ENTRY DLY 4 in the **System Option** section begins to count without displaying on keypad. If the time expires and the zone has not returned to normal, the keypad trouble buzzer starts and CLOSE THE DOOR appears on the keypads programmed into the PREWARN ADDRESS section. The time programmed into ENTRY DLY 4 begins to count down again internally. If the time expires a second time and the zone has not returned to normal, a fault report is sent to the receiver and the zone name - OPEN message displays on the keypads until a code is entered. The bell output does not activate for the Door Propped operation.

SILENCE/RESET - Select S when the zone (not FI, SV, or FV) is connected to a DMP Model 303 Silence/Reset switch, the zone can be used to silence the alarm bell and perform a sensor reset without using a keypad. A report is NOT sent to the receiver except for the bell silence report.

18.15 Output Number

You can specify any of the Relay Outputs on the XR100 Series Canadian panel to be activated by a zone condition (1 to 6, 500 to 599 if Model 716 used, D1 to D8, G1 to G20). The output can be activated regardless of the report to transmit or whether or not the zone is programmed as local. An output activated by an armed zone is turned off when the zone area is disarmed by a user.

To enter an output number, press a top row Select key followed by the output number. Press the COMMAND key.

- 18.16** OUTPUT: NONE **Output Action**
 Entering an Output Number displays this prompt. This prompt allows you to assign an output action to the relay: Steady, Pulse, Momentary, or Follow.
- STD PLS MOM FOLW **STEADY** - The output is turned on and remains on until the area is disarmed, an output cutoff time expires, or the output is reset from the keypad menu.
PULSE - The output alternates one second on and one second off. **Note:** The pulsing rate for a Model 716 relay attached to the LX-Bus is 1.6 seconds.
MOMENTARY - The output is turned on only once for one second.
FOLLOW - The output is turned on and remains on while the zone is in an off normal, or bad condition. When the zone restores, the output is turned off.
Note: For Day Zone types, when an output is turned on, a user code with silence authority can turn the output off.
- After you make the three selections in the sections above, the display prompts you for the same three selections for Disarmed Short, Armed Open, and Armed Short conditions. If the zone is a 24-hour type, only the Armed Open and Armed Short conditions display. When you have programmed all of the zone conditions, the Swinger Bypass selection then displays.
- 18.17** SWGR BYP NO YES **Swinger Bypass**
 Selecting YES allows the zone to be swinger bypassed by the panel according to the specifications programmed in Swinger Bypass Trips and Reset Swinger Bypass. The Bypass condition displays in the keypad Status List. Selecting NO disables swinger bypassing for this zone.
- How it works**
 If within one hour, a zone trips the total number of times AS specified in Swinger Bypass Trips, the panel bypasses it until the following conditions occur; the area in which the zone is assigned is disarmed, the zone is manually reset through the Bypass Zones? keypad User Menu function, the zone remains normal for one hour and the Reset Swinger Bypass is YES.
- If the zone trips fewer than the specified times within one hour, the bypass trip counter returns to 0 (zero) and the process must be repeated.
- A report of the swinger bypass is sent to the receiver if Bypass Reports is YES.
- 18.18** PREWARN KEYPADS: **Prewarn Keypad Addresses**
 At the entry delay start, all keypad addresses selected here display ENTER CODE:-. If you want the prewarn to sound at all 8 addresses, leave the default setting.
- To delete an address, press the matching number on the keypad. To disable prewarning at all keypads, press a top row Select key to clear the addresses shown. Press the COMMAND key when the address selection is complete.
- The prewarn tone stops at the keypad where the first user code digit is entered. If no keys are pressed for five seconds or an invalid user code is entered, the prewarn tone resumes at that keypad.
- 18.19** ENTRY DELAY: 1 **Entry Delay**
 Select the entry timer for this zone. Entry timers 1 to 4 are programmed in System Options.
- 18.20** RETARD NO YES **Zone Retard Delay**
 When you select YES, the zone operates with the zone retard delay. The retard functions only in zone short conditions.
- The zone must remain shorted for the full length of the retard delay before the panel recognizes its condition. If you select NO, the zone operates without a retard delay.
- 18.21** PRESGNL KEYPADS: **Presignal Keypad Addresses**
 You can enable any combination of keypad addresses to sound a presignal tone during the time a zone is in retard delay. The presignal tone silences when the zone restores or the retard delay expires.
- To enable a presignal address, press any top row Select key followed by the number of the keypad address. You can enable the presignal for all 8 keypad addresses.

ZONE INFORMATION

To disable a presignal address press the matching number digit again. Press the COMMAND key when the address selection is complete. The Presignal prompt is only displayed when Retard is selected as YES.

- 18.22** FAST RSP NO YES **Fast Response**
Select YES to provide a zone response time of 167ms. Select NO to provide a normal zone response time of 500ms. Zones 500 to 599 have a fixed response time and do not display this prompt.
- 18.23** CRS ZONE NO YES **Cross Zone**
Select YES to enable cross zoning for this zone. Cross zoning requires one or more armed zones to fault within a programmed time before an alarm report is sent to the receiver. When the first cross zoned zone trips, the cross zone time specified in System Options begins to count down. When a second cross zoned zone trips or the first zone trips a second time before the end of the count down, the bell action assigned to the zone activates and the panel sends an alarm report for both zones. If no other cross zoned zone trips before the cross zone time expires, the panel sends only a zone fault report to the receiver.
Cross zoning is not compatible with all zone types: You can not enable cross zoning for Fire verify zones or for any Fire zones that have Retard Delay enabled.
Note: For UL Installations, Cross Zoned zones must protect the same area.
- 18.24** PRIORITY NO YES **Priority**
Select YES to provide additional protection for the premises by requiring this zone to be in a normal condition before its assigned area can be armed.
- 18.25** FIRE PANEL SLAVE INPUT: NO YES **Fire Panel Slave Input**
This option is available on Fire Zones (FI) only and allows a fire zone the ability to provide slave communication operation for a separate fire alarm control panel. If YES, this zone will transmit a restoral immediately when restored by the fire panel being monitored. A sensor reset is not required to generate the restoral message. If NO, this zone will operate as a standard fire type zone and a sensor reset is required before the zone will return to normal. Default is NO.
- 18.26** FOLLOW AREA: **Area Follower**
Allows Night, Day, Aux 1, or Aux 2 burglary zones to be delayed by following any exit or entry delay that is currently running in the area that is specified. Default is 0.
- 18.27** ZONE REAL-TIME STATUS NO YES **Zone Real-Time Status**
Selecting YES allows Real-Time Status reports, such as Door Open or Closed with zone number, to be sent using PC Log reporting. Selecting NO disables Real-Time Status for this zone. Default is NO.
- 18.28** ZONE AUDIT DAYS: **Zone Audit Days**
Enter the number of days (0 to 365) allowed to elapse without the zone being tripped before a fault message is sent. The message is sent to the receiver(s) programmed to receive Supervisory/Trouble Reports at 10:00 am following the expiration of the timer. Each time the zone is tripped, the Zone Audit Days timer restarts and begins to countdown the number of days programmed. After the countdown expires, a fault message is sent and the Zone Audit Days timer restarts and begins to countdown the number of days programmed. Available for all zone types except fire and fire verify. Enter 0 (zero) to disable this function. Default is 0 (zero).
- 18.29** REPORT WITH ACCT NO. FOR AREA: **Report with Account Number for Area**
This option is only available for 24-hour zone types (Fire, Fire Verify, Panic, Emergency, or Supervisory).
Enter the area number (1-32) to assign as a 24-hour zone type. This option sends the account number of the programmed area with messages. If the entered area number does not exist or is not valid, the account number programmed in the Communication section is sent. Select 0 (zero) to have the report sent with the account number programmed in Communication. Default is 0

Stop

19.1

STOP

Stop

Save Programming

WHEN ANY PANEL PROGRAMMING IS CHANGED, THE STOP ROUTINE MUST BE RUN AND 'SAVING PROGRAM' MUST DISPLAY ON THE KEYPAD IN ORDER TO SAVE THE PROGRAMMING CHANGES.

At the STOP prompt, pressing any Select key allows you to exit the Programmer function of the panel. When selected, the panel performs an internal reset and exits the programmer.

The STOP routine causes the following conditions to occur:

- All 1100 Series DMP Wireless transmitters are reset to NORMAL
- The panel Status List is cleared

During the reset, all keypad displays are momentarily blank for two seconds. After the reset, the programming function terminates and the keypads return to the status list display.

The STOP prompt does not disarm the system. Any new areas or zones that were added during programming are not armed until the system is disarmed and armed again.

Power Up

For 60 seconds after power up on the XR100 Series Canadian panel, any zone transitions are not recognized. Normal zone processing resumes at the end of the 60 seconds.

SET LOCKOUT CODE

Set Lockout Code

20.1

SET LOCKOUT CODE

Set Lockout Code

Pressing COMMAND at the STOP prompt displays SET LOCKOUT CODE. This allows you to program a code that is then required to gain access to the panel internal Programmer through the keypad. You can change this code at any time to any combination of numbers from three to five digits long. You do not need to enter leading zeros when using the lockout code. Initializing the panel does not clear a Lockout Code. Lockout Codes can be changed through Remote Link.

Once you have changed the code, it is important to write it down somewhere and store it in a safe place. Lost Lockout Codes require the panel to be sent back to DMP for repair. You may cancel a Lockout Code by entering 00000 at the Set Lockout Code command.

Lockout Code restriction

Do not set a Lockout Code higher than 65535.

Appendix

21.1 False Alarm Reduction

System Recently Armed report

The System Recently Armed report (S78) is sent to the receiver when a burglary zone goes into alarm within two minutes of the system being armed.

21.2 Diagnostics function

The XR100 Series Canadian panel contains a Diagnostics function that allows you to test the communication integrity of the LX-Bus™, identify individual zones, and also display the present electrical state of any zone. The Diagnostics function also allows you to test the integrity of the cellular communication, cellular signal, and email communication. To use Diagnostics, reset the panel, enter the Diagnostics code 2313 (DIAG), and press COMMAND.

Test LX-Bus

The first Diagnostic function you displayed is: **TEST LX-BUS**. This function allows you to test the ability of the LX-Bus to communicate with zone and output expander modules connected to their LX-Bus circuits. To continue, press any top row Select key. The keypad displays **LX-BUS:**. Using the digit keys, enter the LX-Bus number 1 to test that LX-Bus circuit. The keypad now displays **ADDRESS: -**. Enter a 2-digit LX-Bus device address and press COMMAND. When testing LX-Bus devices, enter only the addresses to which the modules have been set.

Important Note: A device address is not the same as a zone number. If you are testing 714 or 715 Zone Expander Modules, which each contain four zones, the device address is the first zone number. When the panel polls a 714 on the LX-Bus, it recognizes it as a four zone device and does not poll the remaining three zones. The 714 module internally polls the remaining zones and transmits any status changes to the panel. This greatly reduces the amount of time it takes the panel to poll all LX-Bus devices.

The keypad next displays **TESTING . . . STOP** during the device testing. At any time, you can Select **STOP** to end polling. The panel records the number of no responses from the device. If all polls are received back by the panel correctly, the keypad displays **0000/65535 FAIL**.

If one or more polling attempts fail, the keypad displays *** * * */65535 FAIL** with the * representing the number of failed polling attempts. A display of **65535/65535 FAIL** indicates a problem with the interface card or its LX-Bus wiring such as a bad or broken wire, harness not properly connected, or excessive noise or distance. It can also mean that a zone number was entered that did not match a device address. Press the Back Arrow key to enter a new device address or press COMMAND to exit the **TEST LX-BUS**.

Zone Finder

The second Diagnostic function is the Zone Finder. Press COMMAND to display **ZONE FINDER**. This function allows you to identify individual zones on devices connected to the LX-Bus of an interface card, the panel, or any zones on the keypad data bus. To use **ZONE FINDER**, press any top row Select key. The display changes to **FAULT ZONE**. The next zone on the system that changes from a normal to an open or shorted state is displayed as **ZONE NO: * * ***. To continue, press the Back Arrow key.

Zone State

Press the COMMAND to display the third Diagnostic function: **ZONE STATE**. This function allows you to enter any zone number and check its current electrical state (Normal, Open, or Shorted). Press any Select key. The display changes to **ZONE NUMBER: _**. Enter in the zone number you want to check and press COMMAND. The panel displays the current state of the zone as **NRML** (normal), **OPEN**, or **SHORT**.

LX-Bus Status

The fourth Diagnostic function is the **LX-BUS STATUS**. This function allows the panel to poll all devices connected to the LX-Bus of an interface card and check for any Overlapped, Missing, or Extra addresses. Below is a description of each status item:

Overlap - An overlap occurs when one device address is the same as any of the last three zones on another 714 or 715. The overlap feature cannot determine when two devices have the same address.

Example: Model 714 Address 00 = Zones 500 501 502 503, and the Model 711 Address 02 = Zone 502.

Zone 502 would report as an Overlap because both the 714 and 711 have devices set to 502.

Missing - A missing occurs when a zone between 500 and 599 has been programmed in **ZONE INFORMATION** and no device with that zone address has been installed on the LX-Bus. To correct the problem, check your zone programming and zone expansion module addressing.

Extra - A device is installed on the LX-Bus but none of its zones are programmed into the system.

MAC Address

Short for Media Access Control address. This hardware address uniquely identifies each network node. Not to be confused with an IP address, which is assignable. In the Diagnostics function, the MAC address is the panel on-board network hardware address. Press any top row Select key to display the panel MAC address. Press the COMMAND key to view the next prompt.

Serial Number

This number is the network communicator serial number. Reference this number for communicator date-of-manufacture, hardware version, etc. Press any top row Select key to display the Serial Number. Press the COMMAND key to view the next prompt.

Current Flash

This option displays Flash 1 or Flash 2 indicating which physical flash chip the panel is currently using. Press any top row Select key to display the current flash information. Press the COMMAND key to view the next prompt.

Communication Status

This option tests the individual components of cellular or network communication. The displayed results are shown below.

Cellular Results:

Successful Display	Failure Display
MODEM OPERATING	NO MODEM FOUND
SIM CARD READ	NO SIM CARD
TOWER DETECTED	NO TOWER
SIM REGISTERED	NOT REGISTERED



This displays the cellular signal strength of the nearest tower for the SIM card carrier. The bars represent the signal strength 0-7. Select YES to continue through the remaining component tests. Select NO to stop testing and return to the COMM STATUS prompt.

Successful Display	Failure Display
APN ACCEPTED	APN ERROR
COMM PATH GOOD	NO ACK RECEIVED

Network Results:

Successful Display	Failure Display
LINK OK	LINK ERROR
DHCP OK	DHCP ERROR
GATEWAY FOUND	NO GATEWAY
DEST FOUND	NO DESTINATION
COMM PATH GOOD	NOT CONNECTED NO ACK RECEIVED

Cellular Signal Strength (CELL SIGNAL)

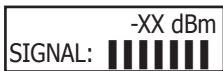

This option provides a way to test the cellular signal strength of the nearest tower for the SIM card carrier. Press any top row Select key to display cell signal strength. The X's represent the numerical value of the cell signal strength in -dBm. The bars represent the signal strength 0-7. The signal strength results are shown below.

Email Status

The Email Status menu tests each component of the panel's e-mail communication. The test proceeds until the first component failure or until all components have been tested with positive results. The test screen displays after each component and displays for two seconds or until the CMD key has been pressed. The displayed results are shown below.

Email Results:

Successful Display	Failure Display
EMAIL ENABLED	EMAIL DISABLED
LINK OK	LINK ERROR
SMTP SERVER OK	INVALID SERVER
DEST ADDRESS OK	DEST ADDR FAILED
CONNECTING	CANNOT CONNECT
AUTH MODE SENT	AUTH MODE FAILED
PASSWORD SENT	BAD PASSWORD (or USERNAME)

Successful Display	Failure Display
FROM ADDR SENT	FROM ADDR FAILED
DEST ADDR SENT	DEST ADDR FAILED
DATA MODE SENT	DATA MODE FAILED
MESSAGE SENT	MSG SEND FAILED
DISCONNECTED	DISCONNECT FAIL
EMAIL SUCCESS	

Exiting the Diagnostics program

To exit the Diagnostics function, press the COMMAND key until STOP displays. Press any Select key to exit the diagnostics function. The keypad returns to the Status List display.

21.3 Using the 984 Command Function

This feature allows you to connect to a service receiver, is used primarily to bring a new account on-line and upload panel programming completed in Remote Link™.

Note: When not in the Programming Menu, the function 984 + COMMAND can be entered at the keypad, and a remote options menu appears. This menu contains the following options:

NUMBER: The panel allows you to enter into the keypad a phone number you want the panel to dial. Enter any required prefixes and area codes. After completing panel programming in Remote Link, set a trap to seize the panel when it calls. Traps are set by selecting Panel > Trap. Refer to the Remote Link User's Guide (LT-0565), or the Remote Link Help File.

Then, from the panel, enter 984 and press the COMMAND key, while the panel is in the Status List. The keypad display changes to **NBR TEST PICKUP**. Press the Select key under **NBR**. Enter the phone number for the service receiver connected to the Remote Link computer. Press each number key slowly and deliberately. The panel dials each number as it is pressed. If you make a mistake, press the Back Arrow key. The panel stops dialing and return to the Status List.

You can enter up to 32 characters for the phone number. Once you have entered 16 characters the LCD display is full: Press the COMMAND key to enter the final 16 characters. To enter a # (pound sign) press the '0' then the fourth (far right) Select key, and to enter an * (asterisk) press the third Select key. Program a pause by entering the letter P. Program CID message communication by entering the letter T in the first position. Cancel call waiting by entering *70P as the first characters. These characters are counted as part of the allowable 32 characters. Press COMMAND after you enter the phone number.

The panel calls the receiver connected to Remote Link to download the new programming. Remote Link then traps the panel.

Note: The panel makes ten attempts to reach the receiver. While attempting to contact the receiver, if the panel needs to send an alarm report, the panel stops dialing and uses the phone line to send its report.

TEST: The panel allows you to perform a Communication Status Test on each component of the panel's cellular or network communication paths. While the Status List displays, enter 984 and press the COMMAND key. The keypad display changes to **NBR TEST PICKUP**. Press the Select key under **TEST** to allow the panel to perform a Communication Status Test. The display prompts the user for a user code to be entered. The user code must have the authority to perform a System Test.

Upon entry of a Cell or Network path when prompted, the test runs and the results display on the keypad. See Diagnostic Functions section for a description of the Communication Status results.

PICKUP: The panel picks up the phone line when Remote Link™ calls in. The phone must be ringing before selecting **PICKUP**. After completing panel programming in Remote Link, connect to the panel by selecting Panel > Connect. Refer to the Remote Link User's Guide (LT-0565), or Help File for complete information about connecting to panels.

While the panel displays in the status list and the telephone line at the panel rings, enter 984 and press the COMMAND key. The keypad display changes to **NBR TEST PICKUP**. Press the Select key under **PICKUP** to allow the panel to seize the line. The panel immediately seizes the phone line and sends a carrier tone to the receiver. A verification process occurs and, if successful, the panel grants remote access to its programming and Event Buffer.

After the panel has seized the line, send the file from Remote Link by selecting Panel > Send. Remote Link then uploads the new programming into the panel. You may also Request Events by selecting Panel > Request Events in Remote Link. The panel begins sending the first event or access that occurred on or after the start date specified by Remote Link and finishes by sending the last event or access that occurred on or before the end date specified by Remote Link. If necessary, a Request Events upload in progress can be cancelled.

Keypad Displays

When either the **RMT** or **PICKUP** options are used, the keypad displays **LINE SEIZED**. This indicates that the panel has seized the line and is executing its program. If the line cannot be accessed, or if the **RMT** or **PICKUP** options are used before all connects attempts are made, the keypad displays **SYSTEM BUSY**.

21.4 Using the Walk Test

The XR100 Series Canadian panel provides a walk test feature that allows a single technician to test the protection devices connected to zones on the system. Conduct the Walk Test within 30 minutes of resetting the panel. The Walk Test automatically ends if no zones are tripped for 20 minutes. **TEST IN PROGRESS** displays at all keypads programmed with the same Area Display features. When five minutes remain, **TEST END WARNING** displays. The Walk Test only tests zones assigned to the areas programmed into the keypad in Area Display. If any areas are armed the Walk Test does not start and **SYSTEM ARMED** displays.

WALK TEST

Walk Test

To conduct the Walk Test, reset the control panel by momentarily placing a jumper on J16. From the keypad, enter the code 8144 and press COMMAND. The keypad displays WALK TEST for four seconds. If the system is monitored and the communication type is DD or NET, the system sends a System Test Begin report to the central station. After four seconds, the keypad displays the zone type choices for testing.

*BG *FI *PN *SV

Zone Types

Select the zone type you want to test. An asterisk next to the zone type indicates the zone type chosen for testing. Press the Select key again to deselect the zone type. When you have selected all the zone types you want for testing, press the COMMAND key to display the next Walk Test option. Pressing the Back Arrow key exits the Walk Test.

BG (Burglary zones) - Select **BG** to test burglary zones. Includes all NT, DY, EX, A1, and A2 zones.

FI (Fire zones) - Select **FI** to test fire zones. Includes all FI and FV zones.

PN (Panic zones) - Select **PN** to test panic zones. Includes all PN and EM zones.

You do **NOT** have to hold the zones for 2 seconds in normal mode. You are only required to hold the panic during the Walk Test because the zone takes additional time to report when the system is in test mode.

SV (Supervisory zones) - Select **SV** to test supervisory zones. Includes all SV zones.

Note: During the Walk Test, trip each zone device or button on the system for 1 to 2 seconds.

WLS PIR

WLS (Wireless Check-in Test) - Select WLS to automatically test wireless transmitter communications. Includes all wireless devices except key fobs and transmitters programmed for a supervision time of 0 (zero).

PIR (Wireless PIR Walk Test) - The PIR Walk Test allows the installer to verify the 1126 operation. When enabled, the 1126 LED flashes each time motion is detected for up to 30 minutes. This is a local test only and no messages are sent to the Central Station.

BELL NO YES

Bell Action

This option selects the bell output action when a zone under test faults. This option allows the panel bell, and/or burglary bell, and/or fire bell to turn ON and then OFF each time a zone is tripped (opened or shorted).

NO - Select NO for no bell output action during Walk Test.

YES - Select YES to turn on any bell output for 2 seconds during Walk Test.

PULS - Select PULS to turn on any bell output for 1/4 second during Walk Test. Any LX-Bus device output turns on for 1.6 seconds due to the polling cycle.

TRIPS: XXX END

Trip Counter For Walk Test

Once in the Walk Test, walk around and trip each protective device. Continue tripping devices until the entire system is tested.

With each zone trip during the Walk Test:

- Keypad display increments each time a selected zone is opened or shorted
- The keypad buzzes for two seconds
- The panel sounds the alarm bells as programmed in Bell Action
- Each time a FI, FV, or SV zone trips, a Sensor Reset occurs.

If **ENHANCED ZONE TEST** is selected as YES:

A Verify message is sent at the time the zone trip occurs instead of at the end of the Walk Test. For FI, FV or SV zone types, the Verify message is sent at the initial trip. For all other zone types, the Verify message is sent when the zone restores. This allows the Central Station to count the number of devices per zone.

END - Select END to stop the Walk Test. When the Walk Test ends or a 20-minute time-out expires, a final Sensor Reset occurs. The System Test End message is sent to the receiver along with Verify and Fail messages for each zone under test.

Faulted zones then display on the keypad.

CKIN:XXX/ZZZ END

Trip Counter For DMP Wireless Check-in Test (WLS)

Displays the number of wireless zones that automatically communicate a supervision check-in message.

- The number of zones that check in. (XXX in the example).
- The total number of wireless zones programmed for supervision that should check in. (ZZZ in the example).

END - Select END to stop the Wireless Check-in Test. When the test ends or a 20-minute time-out expires, normal wireless zone processing returns. If all transmitters check-in, both numbers match within three (3) minutes. If a transmitter has multiple zones (1101, 1114, etc.), all zones are included in the counts. Failed wireless zones display on the keypad.

TEST END WARNING

Test End Warning

When five minutes remain on the 20 minute Walk Test timer, the keypad displays TEST END WARNING . If no additional test zone trips occur, the test ends and a final Sensor Reset automatically occurs. The System Test End message is sent to the receiver along with Verify and Fail messages for each zone under test. Faulted zones then display on the keypad.

SOUTH LOBBY

Failed Zones Display

ZONE: 10 -FAIL

For each zone that did not trip (failed) at least once during the Walk Test, all keypads with matching Area Display programming display the zone name and number and buzz for one second. Any selected (*FI *PN *SV) 24-hour zone that is faulted at the end of the Walk Test displays a trouble condition for that zone regardless of the message programmed for the open or short condition of the zone and a zone trouble is sent to the receiver. Press the COMMAND key to display the next failed zone.

Note: For the Wireless Check-in Test, failed wireless zones display only on the keypad. Zone Verify/Fail reports are not sent to the central station receiver for the wireless check-in test.

21.5 Keypad Speaker Operation

When using LCD Keypads, the panel provides distinct speaker tones from the keypad for Fire, Burglary, Zone Monitor, and Prewarn events. The list below details the conditions under which the speaker is turned on and off for each event.

Fire	On - Fire zone alarm and Bell Output or Fire Bell Output is ON. Off - Alarm Silence.
Burglary	On - Burglary zone alarm and Bell Output or Burglary Bell Output is ON. Off - Alarm Silence.
Zone Monitor	On - One time only when a monitored zone is tripped. Off - After one tone.
Prewarn	On - During Entry Delay. Off - When Entry Delay expires.

21.6 Cross Zoning

Caution must be taken when cross zoning devices to ensure that the Cross Zone Time is long enough to allow an intruder to trip both devices before it expires. A Cross Zone Time that is too short may allow an intruder to trip the devices and allow only a zone fault report be sent to the central station.

When a Cross Zoned zone trips a FAULT report is sent to the SCS-1R Receiver. When two Cross Zoned zones trip within the Cross Zone Time, both zones send ALARM signals to the receiver. For example, if zones 1 and 2 are Cross Zoned zones, and only zone 1 trips, a FAULT report is sent to the receiver for zone 1. If zone 1 trips and zone 2 trips within the Cross Zone Time, an ALARM report is sent to the receiver for zone 1 and zone 2.

21.7 Events Manager

The Events Manager allows you to delay sending certain reports to the central station receiver. Reports can be kept in the panel memory until overwritten by new activity or held until the memory buffer reaches 50 events or 50 door access granted events. When the buffer is full, the panel automatically sends the stored reports to the central station receiver. Below is a list of panel reports you can delay using the Events Manager option.

Report Type	Immediately	Delayed
Alarm	Y	
Trouble	Y	
Restore	Y	
Opening		Y
Closing		Y
Bypass	Y	
Reset	Y	
Supervisory	Y	
Add Codes		Y
Delete Codes		Y
Change Codes		Y
Permanent Schedule Change		Y
Temporary Schedule Change		Y
Door Access		Y
Door Access Denied	Y	
Late to Close	Y	
Force Armed Zone	Y	

21.8 User Profiles

A profile defines the authority of each user code in the system. Profiles are programmed in the Keypad User Menu. Several characteristics associated with each User Profile define its authority within the system. To effectively program an XR100 Series Canadian system, you must understand the interrelationship between profiles, devices, output groups, and areas. Below is a brief explanation of the User Profile elements. For more information about user profiles, refer to the XR500/XR100 User’s Guide (LT-0683).

Profile Number - Each profile may be assigned a unique number from 1 to 99.

Note: Profiles cannot be changed via keypad in an All/Perimeter or Home/Sleep/Away system. Use the default profiles 1 through 10. Refer to the User Profiles Record and the XR500/XR100 User’s Guide (LT-0683).

Profile Name - Each profile may be assigned a 32-character name. The Profile Number is the default name.

Area Number - Each profile may be assigned specific areas of the system for arming and disarming. When creating profiles 1 to 98, NO areas are assigned by default. The default for profile 99 is ALL areas assigned. Profile 99 is preprogrammed in the system at the factory.

Access Area Number - Each profile may be assigned door access area assignments. Default for profile 1 to 98 is NO areas assigned. Default for profile 99 is ALL areas assigned. Profile 99 is preprogrammed at the factory.

Output Group Assignment - Each profile may be assigned an output group number from 1 to 10. Default for profile 1 to 98 is NO output group assigned. Default for profile 99 is output group 10. Your system may be programmed to turn on an output group at certain keypads when door access occurs.

User Menu Assignments - Each user profile may have any of the menus assigned to it as shown in the User Profile Record below. The User Profile Record lists the user menu profile assignments and the system functions users are allowed to access based on the profile numbers assigned to their codes.

Always make sure that at least one administrator in your system has a profile with **all** authorities and areas.

21.9 User Profiles Record

This User Profiles Record can be used as a tool when programming Devices, Profiles, Areas, and Output Groups. Because these programming options are interrelated, use this sheet to plan the system before you begin the installation and programming process.

21.10 Zone Type Descriptions

This section describes applications for the default zone types in Zone Information programming.

-- (Blank Zone)

Customizable zone type. By default, no actions are programmed to occur with Blank Zone. A zone name must be entered to use this zone type: This zone type is not the same as an *UNUSED* zone.

NT (Night Zone)

Controlled instant zone used for perimeter doors and windows and interior devices such as PIRs and Glassbreak detectors.

DY (Day zone)

Used for emergency doors or fire doors to sound the keypad buzzer and display the zone name when the zone is faulted. Day zones also send alarm reports to the receiver during the system armed periods.

Keypad Bus Zone Information	Type	Area	Fire Bell	Disarmed Open			Disarmed Short			Armed Open			Armed Short			Swinger	Prewarn	Entry Delay	Retard Delay	Presignal	Fast Response	Cross Zone	Priority	Follow Area	Real-Time Rpts	Door Number	Style
	Assign Disarm condition of NT, DY, EX, A1, and A2 only	PERIM	INT	Output *	Message	Output *	Action	Message	Output *	Action	Message	Output *	Action	Message	Output *												
Assign Prewarn and Entry Delay for EX only	DY	EX		A	T	L	D	S		A	T	L	D	S			1	1	N	1	N	N	N	0	N	0	TGL
Assign Retard and Presignal for FI, SV, A1, and A2 only	FI	PN		A	T	L	D	S		A	T	L	D	S			1	1	N	1	N	N	N	0	N	0	ARM
Zone Type Defaults	A1	A2	or	A	T	L	D	S		A	T	L	D	S			1	1	N	1	N	N	N	0	N	0	DIS
	FV	AR	1 to 8	A	T	L	D	S		A	T	L	D	S			1	1	N	1	N	N	N	0	N	0	MNT
Night	NT			-	0	S	-	0	S	A	0	S	A	0	S	Y					N	N	N	0	N	0	
Day	DY			T	0	S	T	0	S	A	0	S	A	0	S	Y					N	N	N	0	N	0	
Exit	EX			-	0	S	-	0	S	A	0	S	A	0	S	Y	1-8	1			N	N	N		N	0	
Fire	FI		0							T	0	S	A	0	S	N			N	+	N	N	N				
Panic	PN									T	0	S	A	0	S	N					N	N	N				
Emergency	EM									T	0	S	A	0	S	N					N	N	N				
Supervisory	SV		0							T	0	S	A	0	S	N			N	+	N	N	N				
Auxiliary 1	A1			T	0	S	A	0	S	T	0	S	A	0	S	N			N	+	N	N	N	0	N	0	
Auxiliary 2	A2			T	0	S	A	0	S	T	0	S	A	0	S	N			N	+	N	N	N	0	N	0	
Fire Verify	FV		0							T	0	S	A	0	S	N					N		N				
Arming	AR																									TGL	
Zone Name	*Output Options: 1 to 6, 450 to 474, 480 to 499, 500 to 599, D1 to D8, G1 to G20. + = Set retard to YES before selecting presignal. ■ = Zone functions not available.																										

21.11.1 Keypad Bus Zone Type Defaults

These are complete spellings of the abbreviations used for the zone types, such as Night and Exit.

Type - These are the abbreviations used for the zone types, such as NT and EX.

Area - For an Area system or a Home/Sleep/Away with Guest system this is 1 to 8. For an All/Perimeter or Home/Sleep/Away system, this is the Interior, Bedroom, or Perimeter. Select the area for NT, DY, EX, A1, A2, and AR types.

Fire Bell Out - Only available for FI, FV, and SV zones. Use any output zone number listed.

Message - A = alarm report, T = trouble report, L = local, no report, - (dash) = no report, D = door propped (When SV zone is connected to 303 Silence/Reset Switch), S = sensor reset/alarm silence, C = early morning ambush cancel.

Output - These are 1 to 6 on-board and 500 to 599 off-board relay outputs, 450 to 474 and 480 to 499 wireless outputs, D1 to D8, and G1 to G20.

Action - This selects the action of the output: S = steady, P = pulse, M = momentary, and F = follow

Swinger - The zone can be automatically bypassed after a programmed number of trips.

Prewarn - This selects the keypad address that sounds the entry prewarn for this zone.

Entry Delay - This is the entry delay timer selected as the default for this zone.

Retard Delay - Provides a programmed retard time before an alarm initiates from a shorted zone. When used on an arming zone, the retard delay occurs when the zone is shorted before the armed state has changed. If the arming zone has Maintain as the Style, the retard delay also occurs when the zone returns to a normal state.

Presignal - Provides a keypad tone for zones in retard delay. Retard must be YES before Presignal can be selected.

Fast Response - Provides a 167ms zone response instead of the normal 500ms response.

Cross Zone - Provides cross zoning with any of the 574 zones.

Priority - Requires this zone to be in a normal condition before the area can be armed.

Style - The abbreviations for arming zone style:

TGL = Toggle, ARM = Arm only, DIS = Disarm only, STEP = Wireless arming, MNT = Maintain

21.12 Common Keypad Messages

There are several common keypad messages that the keypad displays to inform the technician and end-user. The common messages are described below. Possible solutions are also provided.

Message	Meaning	Possible Solutions
INVALID AREA	The user has attempted a door access for an area they are not assigned.	Change the user access areas if access to the area is needed. If access is not needed, the user cannot enter the area.
INVALID CODE	The user code you entered is not recognized by the system.	Check the user code and try again.
INVALID PROFILE	A user attempted a function that is outside of the assigned profile.	Check the user profile settings.
INVALID TIME	A user code assigned to a specific schedule has entered outside of the valid schedule.	See Schedules and User Codes.
CLOSING TIME	The scheduled has expired but the area is not armed.	Users still on the premise should arm the system or extend the schedule to a later time.
LATE TO CLOSE	The system was not armed at its scheduled closing time.	Users still on the premise should arm the system or extend the schedule to a later time.
FAILED TO EXIT	A user assigned the anti-passback option has attempted to re-enter an area from which they did not exit properly.	The user must exit the area through the proper door. If not possible, your system administrator should select the Forgive option in the User Codes menu.
AC TROUBLE	The system is not getting proper power.	Check that all AC connections are good.
BATTERY TROUBLE	The battery is either low or missing.	Check that the battery connections are good and the battery is still good.
PHONE LINE 1 TROUBLE	There is trouble with the phone line supervision.	Plug in the phone line.
SYSTEM TROUBLE or SERVICE REQUIRED	There is a problem with one or more components in the system.	Make sure the J16 jumper is removed from the panel. Make sure there is not a short or open condition on the green data wire to the keypad. You may also need to check that all of the keypads and expansion modules on the bus are good.
SYSTEM BUSY	The system is performing another task with a higher priority.	Wait a few moments for the system to complete the task. Make sure the J16 jumper is not on the panel. If the message displays for a long period of time, the processor could be locked up.
4-WIRE BUS TROUBLE	There is not a supervised device on the bus.	Program a device to be supervised.
	There is low voltage or an open yellow wire.	Make sure all wires are connected.
	Two devices share the same address.	Program one of the devices to a unique address.
TRANSMIT FAIL	The panel has attempted to communicate with the central station 10 times and has not succeeded.	Verify your communication type, account number, and phone number. Make sure the telephone line is connected and working properly.
NON-POLLED ADDRESS	The device is not set to DOOR, KEYPAD or FIRE in Device Setup during programming.	Program the device as DOOR, KEYPAD or FIRE in Device Setup.
ENTER CODE (entering Programming)	A lockout code has been programmed for the panel.	Enter the lockout code.
WIRELESS TROUBLE	The panel is unable to communicate with the wireless receiver.	Verify the receiver is properly connected to the panel. Verify the correct House Code is programmed in System Options.
	The wireless receiver is missing.	

21.13 Area Account Number Messages

XR100 systems send an area account number instead of the system account number with the following panel messages/events based on the area assigned to the zone that initiated the alarm:

- WARNING: Alarm Bell Silenced (S34)
- Abort Signal Received (S45)
- Cancel Signal Received (S49)
- ALERT: System Recently Armed (S78)
- ALERT: Exit Error (S80)
- ALARM: Verify Signal Received (S96) (not currently sent on area arming systems)

The XR100 has always sent the area account number for the following messages:

- Zone event messages for all non-24 hour zones assigned to an area
- Arming
- Disarming

The XR100 sends the following messages using the area account number based on the lowest area number in Display Areas programming from the keypad being used:

- User Code Add/Change/Delete
- Door Access/Denied
- User 1 Ambush and Early Morning Ambush
- System Test Begin/End
- Unauthorized Entry
- Service Code and Service Request

The XR100 sends the following messages using the area account number based on the area number:

- Late to Arm for area schedules

Revisions to This Document

This section explains the changes made to this document during this revision. It lists the date and identifies the change(s) made, the related section number and section heading, and a summary of the change.

Guide

Version	Section Number and Heading	Quick Explanation of Changes	
1.12	3.19 First & Second GPRS APN	Changed default	
	4.7 734N listen Port	Added section	
	4.8 734N Passphrase	Added section	
	6.5 Device Communication Type	Added section	
	6.18 Program 734/734N Options	Added 734N/734N-WiFi to section	
	6.18.1 Activate Zone 2 Bypass	Added 734N/734N-WiFi bypass option	
	6.18.2 Zone 2 Soft-Bypass	Added 734N/734N-WiFi bypass option	
	6.18.3 Relock on Zone Change?	Added 734N/734N-WiFi option	
	6.18.6 Activate Onboard Speaker	Added 734N/734N-WiFi default information	
	6.18.8.4 User Code Length	Added 734N/734N-WiFi custom number range	
	6.18.9.1 Site Code Display	Added 734N/734N-WiFi option	
	6.18.11 No Communication with Panel	Added section	
	7.11.1 First & Second GPRS APN	Changed default	
	11.17 Supervisory Alarm Output	Added section	
	19.17 Output Action	Added Day Zone Type information	
	1.11	9.25 Use False Alarm Question	Added section
	1.10	1.2 Getting Started	Added Wireless Keypad information
1.7 Keypads		Added Wireless Keypad	
1.9 Entering Alpha Characters		Added Wireless Keypad info	
1.10 Entering Non-Alpha Characters		Added table showing character locations	
1.11 Keypad Displays Current Prog		Added Wireless Keypad info	
3.29 Door Access Report		Removed cellular restriction note	
6.3 Device Name		Changed title and added info	
6.4 Device Type		Added Device Type section	
6.5 Wireless		Added Wireless section	
6.5.1 Serial Number		Added Serial Number section	
6.5.2 Supervision Time		Added Supervision Time section	
7.7 Alarm Receiver Authorization		Added Alarm Receiver Authorization section	
7.8 Service Receiver Authorization		Added Service Receiver Authorization section	
9.9 Swinger Bypass Trips		Changed number of swinger bypass trips	
9.24 Keypad Armed LED		Added section	
10.4 Bell Output		Added 1135 information	
12.6 Supervision Time		Added 3-minute note	
12.7 Trip with Panel Bell Option		Added Trip with Panel Bell Option section	
18.10.3 Supervision Time		Added 3-minute supervision time information	
18.11.3 Key Fob Supervision Time		Removed 3 minutes from display	
21.2 Diagnostics Function		Added Signal strength information	
1.09	9.23 Dual EOL	Added 714, 714-8/16 information	
1.08	6.4 Access Areas	Added statement about door locking	
	6.7 Strike Time	Added device type information	
	6.8 Strike Delay	Added device type information	
	6.13 Door Real-Time Status	Added Door Real-Time Status prompt	
	6.14 Send Door Forced Message	Added Send Door Forced Message prompt	
	6.15 Program 734 Options	Added Program 734 Options prompts	
	7 Remote Options	Complete restructure and reorganization	
	7.2 Remote Key	Allow up to 16 characters	
	7.4 Allow Dialer Remote	Added Allow Dialer Remote prompt	
	7.5 Allow Network Remote	Added Allow Network remote prompts	
	7.6 Allow Cellular Remote	Added Allow Cell Remote prompts	
	7.7 Entré Connection	Added Entré Connection prompts	
	18.29 Report with Acct Number for Area	Added Report with Account Number for Area prompt	

Listings and Approvals

This Class A digital apparatus complies with Canadian ICES-003

ANSI/SIA CP-01-2010 False Alarm Reduction

Underwriters Laboratories Canada (ULC) Listed

ULC S545	Household Fire
ULC Subject-C1023	Household Burglar
ULC/ORD-C1076	Proprietary Burglar
ULC S304-06	Central Station Burglar



800-641-4282

www.dmp.com

Made in the USA

INTRUSION • FIRE • ACCESS • NETWORKS

2500 North Partnership Boulevard

Springfield, Missouri 65803-8877